



SYLLABUS

DIPLOMA IN ELECTRICAL AND ELECTRONICS ENGINEERING

FULL TIME, SANDWICH & PART TIME

Course Code: 1030/2030/3030

2011-2012

L - SCHEME



**DIRECTORATE OF TECHNICAL EDUCATION
GOVERNMENT OF TAMILNADU**

Diploma in Electrical and Electronics Engineering L – Scheme (with effect from 2011-2012)

Everything is changing – that too, at a faster rate in Science and Technology. The adaptability to change leads to Improvement and Development. In Technology front many concepts are becoming obsolete and new concepts are coming in. With the tremendous developments in the field of Electronics, many things that were considered as impossible in the field of electrical engineering have become possible. Anything which is newly invented and developed is becoming obsolete at the moment it is commercially launched. To cope up with this situation, the educational systems must go on updating their curriculum at frequent intervals.

Conventional studies of Electrical Engineering include the areas such as Generation, Transmission, Distribution, Design and Manufacture of Electrical machines. With the developments in nanotechnology, micro-machining became possible and Energy Efficient Micro-Electro-Mechanical Machines were developed. A new subject on 'Special Electrical Machines' is introduced in this L-scheme.

Electrical Energy has already become one of the basic needs of mankind. As the necessity increases, scarcity arises. Yes the present Energy scenario is inability to match the Demand with the Supply. So proper accountability of energy consumption is required. Energy conservation, Energy Management and Energy Auditing play important roles in these days. The newly introduced 'Electrical Estimation and Energy Auditing' subject will be helpful to the students to acquire a comprehensive knowledge on the above said areas.

Diploma students are being employed as technicians in the industries and the industries use the recent technology. To make the Diploma students employable, the curriculum must be in tune with the Latest Technology.. In Medical Field with the introduction of many state-of-art equipments, presence of Instrumentation Engineers in every Hospital became a mandatory requirement. In order to train the student in the Instrumentation field subjects like 'Transducers and Signal Conditioners', 'Bio-Medical Instrumentation - Theory and Practical' are introduced.

The present trend in Electronics is that to design, construct and test the performance of any circuit on computers using appropriate software and then fabricate them using real components. To impart some skills on simulation software, a practical subject on 'Electrical Circuit Simulation' is introduced.

All the above said requirements were considered and due emphasis was given to the recent developments. Some of the obsolete portions were removed. This new curriculum is an attempt to make our students to be more compatible to the changing scenario in the field of Electrical Engineering and to make them as efficient Technicians.

DIPLOMA COURSES IN ENGINEERING/TECHNOLOGY (SEMESTER SYSTEM)

(Implemented from 2011- 2012)

L – SCHEME

REGULATIONS*

* *Applicable to the Diploma Courses other than Diploma in Hotel Management & Catering Technology and the Diploma Courses offered through MGR Film Institute, Chennai.*

1. Description of the Course:

a. Full Time (3 years)

The Course for the Full Time Diploma in Engineering shall extend over a period of three academic years, consisting of 6 semesters[❖] and the First Year is common to all Engineering Branches.

b. Sandwich (3½ years)

The Course for the Sandwich Diploma in Engineering shall extend over a period of three and half academic years, consisting of 7 semesters[❖] and the First Year is common to all Engineering Branches. The subjects of three years full time diploma course being regrouped for academic convenience.

During 4th and/or during 7th semester the students undergo industrial training for six months/ one year. Industrial training examination will be conducted after completion of every 6 months of industrial training

c. Part Time (4 years)

The course for the Part Time Diploma in Engineering shall extend over a period of 4 academic years containing of 8 semesters[❖], the subjects of 3 year full time diploma courses being regrouped for academic convenience.

- ❖ Each Semester will have 16 weeks duration of study with 35 hrs. /Week for Regular Diploma Course and 18 hrs. / Week for Part-Time Diploma Course.

The Curriculum for all the 6 Semesters of Diploma courses (Engineering & Special Diploma Courses viz. Textile Technology, Leather Technology, Printing Technology, Chemical Technology etc.) have been revised and revised curriculum is applicable for the candidates admitted from 2011 – 2012 academic year onwards.

2. Condition for Admission:

Condition for admission to the Diploma courses shall be required to have passed in The S.S.L.C Examination of the Board of Secondary Education, Tamilnadu.

(Or)

The Anglo Indian High School Examination with eligibility for Higher Secondary Course in Tamilnadu

(Or)

The Matriculation Examination of Tamil Nadu.

(Or)

Any other Examinations recognized as equivalent to the above by the Board of Secondary Education, Tamilnadu.

Note: In addition, at the time of admission the candidate will have to satisfy certain minimum requirements, which may be prescribed from time to time.

3. Admission to Second year (Lateral Entry):

A pass in HSC (Academic) or (Vocational) courses mentioned in the Higher Secondary Schools in Tamilnadu affiliated to the Tamilnadu Higher Secondary Board with eligibility for university Courses of study or equivalent examination, & Should have studied the following subjects

Sl. No	Courses	H.Sc Academic		
		Subjects Studied	Subjects Studied	
			Related subjects	Vocational subjects
1.	All the Regular and Sandwich Diploma Courses	Maths, Physics & Chemistry	Maths / Physics / Chemistry	Related Vocational Subjects Theory & Practical
2.	Diploma Course in Modern Office Practice	English & Accountancy English & Elements of Economics English & Elements of Commerce	English & Accountancy, English & Elements of Economics, English & Management Principles & Techniques, English & Typewriting	Accountancy & Auditing, Banking, Business Management, Co-operative Management, International Trade, Marketing & Salesmanship, Insurance & Material Management, Office Secretary ship.

- For the Diploma Courses related with Engineering/Technology, the related / equivalent subjects prescribed along with Practicals may also be taken for arriving the eligibility.
- Branch will be allotted according to merit through counseling by the respective Principal as per communal reservation.
- For admission to the Textile Technology, Leather Technology, Printing Technology, Chemical Technology and Modern Office Practice Diploma courses the candidates studied the related subjects will be given first preference.
- *Candidates who have studied Commerce Subjects are not eligible for Engineering Diploma Courses.*

4. Age Limit: No Age limit.

5. Eligibility for the Award of Diploma:

No candidate shall be eligible for the Diploma unless he/she has undergone the prescribed course of study for a period of not less than 3 academic years in any institution affiliated to the State Board of Technical Education and Training, Tamilnadu, when joined in First Year and two years if joined under Lateral Entry scheme in the second year and passed the prescribed examination.

The minimum and maximum period for completion of Diploma Courses are as given Below:

Diploma Course	Minimum Period	Maximum Period
Full Time	3 Years	6 Years
Full Time(Lateral Entry)	2 Years	5 Years
Sandwich	3½ Years	6½ Years
Part Time	4 Years	7 Years

6. Subjects of Study and Curriculum outline:

The subjects of study shall be in accordance with the syllabus prescribed from time to time, both in theory and practical subjects. The curriculum outline is given in Annexure - I

7. Examinations:

Board Examinations in all subjects of all the semesters under the scheme of examinations will be conducted at the end of each semester.

The internal assessment marks for all the subjects will be awarded on the basis of continuous internal assessment earned during the semester concerned. For each subject 25 marks are allotted for internal assessment and 75 marks are allotted for Board Examination.

8. Continuous Internal Assessment:

A. For Theory Subjects:

The Internal Assessment marks for a total of 25 marks, which are to be distributed as follows:

i) Subject Attendance

5 Marks

(Award of marks for subject attendance to each subject Theory/Practical will be as per the range given below)

80% - 83%	1 Mark
84% - 87%	2 Marks
88% - 91%	3 Marks
92% - 95%	4 Marks
96% - 100%	5 Marks

ii) Test

10 Marks

2 Tests each of 2 hours duration for a total of 50 marks are to be conducted. Out of which the best one will be taken and the marks to be reduced to:

05 marks

The Test – III is to be the Model test covering all the five units and the marks so obtained will be reduced to :

05 marks

Total 10 marks

TEST	UNITS	WHEN TO CONDUCT	MARKS	DURATION
Test I	Unit – I & II	End of 6 th week	50	2 Hrs
Test II	Unit – III & IV	End of 12 th week	50	2 Hrs
Test III	Model Examination - Compulsory Covering all the 5 Units. (Board Examinations-question paper-pattern).	End of 16 th week	75	3 Hrs

- From the Academic year 2011-2012 onwards.

Question Paper Pattern for the Periodical Test :(Test - I & Test- II)

14 Questions X 1 mark	14 marks
6 Questions X 6 marks	}	36 marks
(OR) 3 Questions X 12 marks		
Total		50 marks

iii) Assignment

10 Marks

For each subject Three Assignments are to be given each for 20 marks and the average marks scored should be reduced for 10 marks

All Test Papers and Assignment notebooks after getting the signature with date from the students must be kept in the safe custody in the Department for verification and audit. It should be preserved for 2 Semesters and produced to the flying squad and the inspection team at the time of inspection/verification.

B. For Practical Subjects:

The Internal Assessment mark for a total of 25 marks which are to be distributed as follows:-

a) Attendance	: 5 Marks	(Award of marks same as theory subjects)
b) Procedure/ observation and tabulation/ Other Practical related Work	: 10 Marks	
c) Record writing	: 10 Marks	
TOTAL	: 25 Marks	

- All the Experiments/Exercises indicated in the syllabus should be completed and the same to be given for final Board examinations.
- The Record for every completed exercise should be submitted in the subsequent Practical classes and marks should be awarded for 20 for each exercise as per the above allocation.
- At the end of the Semester, the average marks of all the exercises should be calculated for 20 marks and the marks awarded for attendance is to be added to arrive at the internal assessment mark for Practical. (20+5=25 marks)
- The students have to submit the duly signed bonafide record note book/file during the Practical Board Examinations.

- All the marks awarded for assignments, Tests and attendance should be entered in the Personal Log Book of the staff, who is handling the subject. This is applicable to both Theory and Practical subjects.

9. Communication and Life Skills Practical:

The Communication and Life Skills Practical with more emphasis is being introduced in IV Semester for Circuit Branches and in V Semester for other branches of Engineering.

Much Stress is given on:

- ❖ Monodic Communication
- ❖ Dyadic Communication
- ❖ Professional Communication
- ❖ Pronunciation
- ❖ Writing Resumes
- ❖ Interview Techniques

Internal Assessment Mark

..... **25 Marks**

10. Project Work:

The students of all the Diploma Courses (**except Diploma in Modern Office Practice**) have to do a Project Work as part of the Curriculum and in partial fulfillment for the award of Diploma by the State Board of Technical Education and Training, Tamilnadu. In order to encourage students to do worthwhile and innovative projects, every year prizes are awarded for the best three projects i.e. institution wise, region wise and state wise. **The Project work must be reviewed twice in the same semester.**

a) Internal assessment mark for Project Work & Viva Voce:

Project Review I	...	10 marks	
Project Review II	...	10 marks	
Attendance	...	05 marks	(Award of marks same as theory Subject pattern)

Total	...	25 marks	

Proper record to be maintained for the two Project Reviews, and It should be preserved for 2 Semesters and produced to the flying squad and the inspection team at the time of inspection/verification.

b) Allocation of Marks for Project Work & Viva Voce in Board Examinations:

Viva Voce	...	25 marks
Demonstration/Presentation	...	20 marks

Total	...	45 marks

c) Written Test Mark (from 3 topics for 1 hour duration): \$

i) Entrepreneurship	5 questions X 2 marks	=	10 marks
ii) Environment Management	5 questions X 2 marks	=	10 marks
iii) Disaster Management	5 questions X 2 marks	=	10 marks

			30 marks

- \$ - Selection of Questions should be from Question Bank, by the External Examiner.
No choice need be given to the candidates.

Project Work & Viva Voce in Board Examination	--	45 Marks
Written Test Mark (from 3 topics for 1 hour duration)	--	30 Marks
TOTAL	--	75 Marks

A neatly prepared PROJECT REPORT as per the format has to be submitted by individual student during the Project Work & Viva Voce Board examination.

11. Scheme of Examinations:

The Scheme of examinations for subjects is given in **Annexure - II.**

12. Criteria for Pass:

1. No candidate shall be eligible for the award of Diploma unless he/she has undergone the prescribed course of study successfully in an institution approved by AICTE and affiliated to the State Board of Technical Education & Training, Tamil Nadu and pass all the subjects prescribed in the curriculum.
2. A candidate shall be declared to have passed the examination in a subject if he/she secures not less than *40% in theory subjects* and *50% in practical subjects* out of the total prescribed maximum marks including both the Internal Assessment and the Board Examinations marks put together, subject to the condition that he/she secures at least a minimum of *30 marks out of 75 marks in the Board Theory Examinations* and a *minimum of 35 marks out of 75 marks in the Board Practical Examinations.*

13. Classification of successful candidates:

Classification of candidates who passed out the final examinations from April 2014 onwards (Joined in first year in 2011-2012) will be done as specified below.

First Class with Distinction:

A candidate will be declared to have passed in **First Class with Distinction** if he/she secures not less than 75% of the aggregate marks in all semesters put together except I and II semesters and passes all the above semesters in the first appearance itself and completes all subjects including that of I & II semesters within the stipulated period of study 3/ 3½/ 4 years (Full Time/Sandwich/Part Time) without any break in study.

First Class:

A candidate will be declared to have passed in **First Class** if he/she secures not less than 60% of the aggregate marks in all semesters put together except I & II semesters and completes all subjects including that of the I & II semesters within the stipulated period of study 3/ 3½ / 4 years (Full Time/Sandwich/Part Time) without any break in study.

Second Class:

All other successful candidates will be declared to have passed in **Second Class.**

The above mentioned classifications are also applicable for the Sandwich / Part-Time students who passed out Final Examination from October 2014 /April 2015 onwards (both joined in First Year in 2011-2012)

14. **Duration of a period in the Class Time Table:**

The duration of each period of instruction is 1 hour and the total period of instruction hours excluding interval and Lunch break in a day should be uniformly maintained as 7 hours corresponding to 7 periods of instruction (Theory & Practical).

-xx-

DRAFT SYLLABUS

Chairperson
Thiru. Ramesh Chand Meena, I.A.S.,
 Commissioner of Technical Education
 Directorate of Technical Education
 Chennai – 600 025.

Convener cum Coordinator
V.Subbaraj M.E, B.Tech.Ed HOD / EEE & Vice-Principal TamilNadu Polytechnic College Madurai – 625 011

Committee Members			
SI No.	Name, Designation and Address	SI No.	Name, Designation and Address
1	M.Arunachalam B.E HOD / Electrical Govt. Polytechnic College Coimbatore – 641 014	6	K.Sourirajan B.E., Dip.T.T Principal Theni Kammavar Sangam Polytechnic College Theni Road, Koduvilarpatti, THENI – 625 534
2	V.Pandian M.E HOD / Electrical Govt. Polytechnic College Bagayam Road, Vellore – 632 002	7	T.Mariari Theodore M.E HOD / Electrical IRT Polytechnic College Tirunelveli – 627 007
3	K.Avinasilingam B.E Lecturer (Selection Grade) / Electrical Govt. Polytechnic College MELUR, Madurai District	8	A.Sahayaraj B.E.,M.B.A.,M.Phil Executive Engineer Tamil Nadu Electricity Board Thiruppathur
4	M.Ravi M.E Lecturer / Electrical Govt. Polytechnic College Thuvakkudimalai Post TRICHIRAPPALLI – 620 022	9	V.Ramprakash B.E Managing Director Industrial Electronics Corporation K.Pudur, MADURAI – 625 007
5	SP.Alagappan B.E Lecturer (Selection Grade) / Electrical Annamalai Polytechnic College Chettinad – 630 102	10	Prof. S.Sivakumar M.E Associate Professor / Electrical Thiagarajar College of Engineering Madurai - 625 015

ANNEXURE-I
CURRICULUM OUTLINE
Diploma in Electrical and Electronics Engineering (Full Time)(1030)
L – Scheme

III SEMESTER

Subject Code	SUBJECT	HOURS PER WEEK		
		Theory Hours	Practical Hours	Total Hours
23031	Electrical Circuit Theory	5	---	5
23032	Electrical Machines - I	5	---	5
24031	Electronic Devices and Circuits *	5	--	5
23034	Electrical Circuits and Machines Practical	---	6	6
24034	Electronic Devices and Circuits Practical *	---	6	6
23036	Work Shop Practical	---	4	4
20001	Computer Applications Practical #	---	4	4
Total Hours		15	20	35

* Common with ECE branch

Common with ALL branches

IV SEMESTER

Subject Code	SUBJECT	HOURS PER WEEK		
		Theory Hours	Practical Hours	Total Hours
23041	Electrical Machines - II	5	---	5
23042	Measurements and Instruments	5	---	5
24043	Digital Electronics *	5	---	5
23044	Transducers and Signal Conditioners	4	6	4
23045	Electrical Machines and Instrumentation Practical	---	6	6
24045	Digital Electronics & Linear Integrated Circuits Practical *	---	4	6
20002	Communication and Life Skill Practice #	---		4
Total Hours		19	16	35

* Common with ECE branch

Common with ALL branches

V SEMESTER

Subject Code	SUBJECT	HOURS PER WEEK		
		Theory Hours	Practical Hours	Total Hours
23051	Power System – I	5	---	5
24052	Micro Controller *	5	---	5
23053	Special Electrical Machines	5	---	5
	Elective Theory – I	5	---	5
23055	Electrical Circuits Simulation Practical	---	5	5
24055	Micro Controller Practical *	---	5	5
	Elective Practical – I	---	5	5
Total Hours		20	15	35

* Common with ECE branch

ELECTIVE SUBJECTS			
Any one of the following theory subject with the corresponding practical may be selected as Elective-I			
Elective Theory – I		Elective Practical – I	
23071	Control of Electrical Machines	23074	Control of Electrical Machines Practical
23072	Programmable Logic Controller	23075	Programmable Logic Controller Practical
23073	Electrical Machine Design	23076	Electrical Machine Design Practical

VI SEMESTER

Subject Code	SUBJECT	HOURS PER WEEK		
		Theory Hours	Practical Hours	Total Hours
23061	Power System – II	6	---	6
23062	Electrical Estimation and Energy Auditing	5	---	5
	Elective Theory – II	5	---	5
23064	Wiring and Winding Practical	---	6	6
23065	Computer Aided Electrical Drawing	---	5	5
	Elective Practical – II	---	5	5
23067	Project Work	---	3	3
Total Hours		16	19	35

ELECTIVE SUBJECTS			
Any one of the following theory subject with the corresponding practical may be selected as Elective-II			
Elective Theory – II		Elective Practical – II	
23081	Power Electronics	23084	Power Electronics Practical
23082	Bio-Medical Instrumentation	23085	Bio – Medical Instrumentation Practical
24682	Computer Hardware and Networks @	24684	Computer Hardware and Networks Practical @

@ Common with Information Technology

CURRICULUM OUTLINE
Diploma in Electrical and Electronics Engineering (Part Time)(3030)
L – Scheme

III SEMESTER

Subject Code	SUBJECT	HOURS PER WEEK			
		Theory Hours	Drawing Hours	Practical Hours	Total Hours
23031	Electrical Circuit Theory	5	---	---	5
23032	Electrical Machines - I	5	---	---	5
20016	Engineering Graphics - I		4		4
23034	Electrical Circuits and Machines Practical	---	---	6	6
23036	Workshop Practical	---	---	4	4
Total Hours		10	4	10	24

IV SEMESTER

Subject Code	SUBJECT	HOURS PER WEEK			
		Theory Hours	Drawing Hours	Practical Hours	Total Hours
24031	Electronic Devices and Circuits *	5	---	---	5
23044	Transducers and Signal Conditioners	4	---	---	4
20026	Engineering Graphics - II	---	4	---	4
24034	Electronic Devices and Circuits Practical *	---	---	5	5
20001	Computer Applications Practical #	---	---	4	4
Total Hours		9	4	9	22

* Common with ECE branch

Common with ALL branches

V SEMESTER

Subject Code	SUBJECT	HOURS PER WEEK		
		Theory Hours	Practical Hours	Total Hours
23041	Electrical Machines - II	5		5
23042	Measurements and Instruments	4		4
24043	Digital Electronics *	5		5
23045	Electrical Machines and Instrumentation Practical		6	6
24045	Digital Electronics and Linear Integrated Circuits Practical *		4	4
Total Hours		14	10	24

* Common with ECE branch

VI SEMESTER

Subject Code	SUBJECT	HOURS PER WEEK		
		Theory Hours	Practical Hours	Total Hours
23051	Power System - I	5	---	5
23053	Special Electrical Machines	5	---	5
23055	Electrical Circuits Simulation Practical	---	5	5
23065	Computer Aided Electrical Drawing	---	5	5
20002	Communication and Life Skill Practical #	---	4	4
Total Hours		10	14	24

Common with ALL branches

VII SEMESTER

Subject Code	SUBJECT	HOURS PER WEEK		
		Theory Hours	Practical Hours	Total Hours
24052	Micro Controller *	5	---	5
23062	Electrical Estimation and Energy Auditing	5	---	5
	Elective Theory – I	5	---	5
24055	Micro Controller Practical *	---	4	4
	Elective Practical – I	---	5	5
Total Hours		15	9	24

ELECTIVE SUBJECTS			
Any one of the following theory subject with the corresponding practical may be selected as Elective-I			
Elective Theory – I		Elective Practical – I	
23071	Control of Electrical Machines	23074	Control of Electrical Machines Practical
23072	Programmable Logic Controller	23075	Programmable Logic Controller Practical
23073	Electrical Machine Design	23076	Electrical Machine Design Practical

VIII SEMESTER

Subject Code	SUBJECT	HOURS PER WEEK		
		Theory Hours	Practical Hours	Total Hours
23061	Power System - II	6	---	6
	Elective Theory – II	5	---	5
23064	Wiring and Winding Practical	---	4	4
	Elective Practical – II	---	5	5
23067	Project Work	---	3	3
Total Hours		11	12	23

ELECTIVE SUBJECTS			
Any one of the following theory subject with the corresponding practical may be selected as Elective-II			
Elective Theory – II		Elective Practical – II	
23081	Power Electronics	23084	Power Electronics Practical
23082	Bio-Medical Instrumentation	23085	Bio – Medical Instrumentation Practical
24682	Computer Hardware and Networks @	24684	Computer Hardware and Networks Practical @

@ Common with Information Technology

CURRICULUM OUTLINE
Diploma in Electrical and Electronics Engineering (Sandwich)(2030)
L – Scheme

III SEMESTER

Subject Code	SUBJECT	HOURS PER WEEK		
		Theory Hours	Practical Hours	Total Hours
23031	Electrical Circuit Theory	5	---	5
23032	Electrical Machines - I	5	---	5
24031	Electronic Devices and Circuits *	5	---	5
23042	Measurements and Instruments	4	---	4
23034	Electrical Circuits and Machines Practical	---	4	4
24034	Electronic Devices and Circuits Practical *	---	4	4
23036	Work Shop Practical	---	4	4
20001	Computer Applications Practical #	---	4	4
Total Hours		19	16	35

* Common with ECE branch
Common with ALL branches

IV SEMESTER

Subject Code	SUBJECT	HOURS PER WEEK		
		Theory Hours	Practical Hours	Total Hours
23041	Electrical Machines -II	--	--	--
23045	Electrical Machines and Instrumentation Practical	--	--	--
20002	Communication and Life Skill Practice #	--	--	--
23091	In plant Training	--	--	--
Total Hours		---	---	---

Common with ALL branches

V SEMESTER

Subject Code	SUBJECT	HOURS PER WEEK		
		Theory Hours	Practical Hours	Total Hours
23051	Power System – I	5	---	5
24043	Digital Electronics *	5	---	5
23044	Transducers and Signal Conditioners	4	---	4
23053	Special Electrical Machines	4	---	4
	Elective Theory – I	5	---	5
23055	Electrical Circuits Simulation Practical	---	4	4
24055	Digital Electronics and Linear Integrated Circuits Practical *	---	4	4
	Elective Practical – I	---	4	4
Total Hours		23	12	35

* Common with ECE branch

ELECTIVE SUBJECTS

Any one of the following theory subject with the corresponding practical may be selected as Elective-I

Elective Theory – I		Elective Practical – I	
23071	Control of Electrical Machines	23074	Control of Electrical Machines Practical
23072	Programmable Logic Controller	23075	Programmable Logic Controller Practical
23073	Electrical Machine Design	23076	Electrical Machine Design Practical

VI SEMESTER

Subject Code	SUBJECT	HOURS PER WEEK		
		Theory Hours	Practical Hours	Total Hours
23061	Power System – II	5	---	5
23062	Electrical Estimation and Energy Auditing	4	---	4
24052	Micro Controller *	5	---	5
	Elective Theory – II	5	---	5
23064	Wiring and Winding Practical	---	4	4
24055	Micro Controller Practical *	---	4	4
23065	Computer Aided Electrical Drawing	---	4	4
	Elective Practical – II	---	4	4
Total Hours		19	16	35

* Common with ECE branch

ELECTIVE SUBJECTS			
Any one of the following theory subject with the corresponding practical may be selected as Elective-II			
Elective Theory – II		Elective Practical – II	
23081	Power Electronics	23084	Power Electronics Practical
23082	Bio-Medical Instrumentation	23085	Bio – Medical Instrumentation Practical
24682	Computer Hardware and Networks @	24684	Computer Hardware and Networks Practical @

@ Common with Information Technology

VII SEMESTER

Subject Code	SUBJECT	HOURS PER WEEK		
		Theory Hours	Practical Hours	Total Hours
23067	Project Work	---	---	---
23092	In Plant Training	---	---	---
Total Hours		---	---	---

DRAFT SYLLABUS

ANNEXURE -II
SCHEME OF THE EXAMINATION
Diploma in Electrical and Electronics Engineering (Full Time)(1030)
L – Scheme

III SEMESTER

Subject Code	SUBJECT	EXAMINATION MARKS			Minimum for PASS	Duration of Exam
		Internal Assessment Marks	Board Exam Marks	Total Marks		
23031	Electrical Circuit Theory	25	75	100	40	3
23032	Electrical Machines - I	25	75	100	40	3
24031	Electronic Devices and Circuits *	25	75	100	40	3
23034	Electrical Circuits and Machines Practical	25	75	100	50	3
24034	Electronic Devices and Circuits Practical *	25	75	100	50	3
23036	Work Shop Practical	25	75	100	50	3
20001	Computer Applications Practical #	25	75	100	50	3
Total		175	525	700	320	

* Common with ECE branch
Common with ALL branches

IV SEMESTER

Subject Code	SUBJECT	EXAMINATION MARKS			Minimum for PASS	Duration of Exam
		Internal Assessment Marks	Board Exam Marks	Total Marks		
23041	Electrical Machines - II	25	75	100	40	3
23042	Measurements and Instruments	25	75	100	40	3
24043	Digital Electronics *	25	75	100	40	3
23044	Transducers and Signal Conditioners	25	75	100	40	3
23045	Electrical Machines and Instrumentation Practical	25	75	100	50	3
24045	Digital Electronics & Linear Integrated Circuits Practical *	25	75	100	50	3
20002	Communication and Life Skill Practice #	25	75	100	50	3
Total		175	525	700	310	

* Common with ECE branch

Common with ALL branches

V SEMESTER

Subject Code	SUBJECT	EXAMINATION MARKS			Minimum for PASS	Duration of Exam
		Internal Assessment Marks	Board Exam Marks	Total Marks		
23051	Power System – I	25	75	100	40	3
24052	Micro Controller *	25	75	100	40	3
23053	Special Electrical Machines	25	75	100	40	3
	Elective Theory – I	25	75	100	40	3
23055	Electrical Circuits Simulation Practical	25	75	100	50	3
24055	Micro Controller Practical *	25	75	100	50	3
	Elective Practical – I	25	75	100	50	3
Total		175	525	700	310	

* Common with ECE branch
Common with ALL branches

ELECTIVE SUBJECTS

Any one of the following theory subject with the corresponding practical may be selected as Elective-I

Elective Theory – I		Elective Practical – I	
23071	Control of Electrical Machines	23074	Control of Electrical Machines Practical
23072	Programmable Logic Controller	23075	Programmable Logic Controller Practical
23073	Electrical Machine Design	23076	Electrical Machine Design Practical

VI SEMESTER

Subject Code	SUBJECT	EXAMINATION MARKS			Minimum for PASS	Duration of Exam
		Internal Assessment Marks	Board Exam Marks	Total Marks		
23061	Power System – II	25	75	100	40	3
23062	Electrical Estimation and Energy Auditing	25	75	100	40	3
	Elective Theory – II	25	75	100	40	3
23064	Wiring and Winding Practical	25	75	100	50	3
23065	Computer Aided Electrical Drawing	25	75	100	50	3
	Elective Practical – II	25	75	100	50	3
23067	Project Work	25	75	100	50	3
Total		175	525	700	320	

ELECTIVE SUBJECTS

Any one of the following theory subject with the corresponding practical may be selected as Elective-II

Elective Theory – II		Elective Practical – II	
23081	Power Electronics	23084	Power Electronics Practical
23082	Bio-Medical Instrumentation	23085	Bio – Medical Instrumentation Practical
24682	Computer Hardware and Networks @	24684	Computer Hardware and Networks Practical @

@ Common with Information Technology

SCHEME OF THE EXAMINATION
Diploma in Electrical and Electronics Engineering (Part Time) (3030)
L-SCHEME

III SEMESTER

Subject Code	SUBJECT	EXAMINATION MARKS			Minimum for PASS	Duration of Exam
		Internal Assessment Marks	Board Exam Marks	Total Marks		
23031	Electrical Circuit Theory	25	75	100	40	3
23032	Electrical Machines - I	25	75	100	40	3
20016	Engineering Graphics - I	25	75	100	40	3
23034	Electrical Circuits and Machines Practical	25	75	100	50	3
23036	Workshop Practical	25	75	100	50	3
Total		125	375	500	220	

IV SEMESTER

Subject Code	SUBJECT	EXAMINATION MARKS			Minimum for PASS	Duration of Exam
		Internal Assessment Marks	Board Exam Marks	Total Marks		
24031	Electronic Devices and Circuits *	25	75	100	40	3
23044	Transducers and Signal Conditioners	25	75	100	40	3
20026	Engineering Graphics - II	25	75	100	40	3
24034	Electronic Devices and Circuits Practical *	25	75	100	50	3
20001	Computer Applications Practical #	25	75	100	50	3
Total		125	375	500	220	

* common with ECE Branch

common with ALL branches

V SEMESTER

Subject Code	SUBJECT	EXAMINATION MARKS			Minimum for PASS	Duration of Exam
		Internal Assessment Marks	Board Exam Marks	Total Marks		
23041	Electrical Machines - II	25	75	100	40	3
23042	Measurements and Instruments	25	75	100	40	3
24043	Digital Electronics *	25	75	100	40	3
23045	Electrical Machines and Instrumentation Practical	25	75	100	50	3
24045	Digital Electronics and Linear Integrated Circuits Practical *	25	75	100	50	3
Total		125	375	500	220	

* Common with ECE branch

VI SEMESTER

Subject Code	SUBJECT	EXAMINATION MARKS			Minimum for PASS	Duration of Exam
		Internal Assessment Marks	Board Exam Marks	Total Marks		
23051	Power System - I	25	75	100	40	3
23053	Special Electrical Machines	25	75	100	40	3
23055	Electrical Circuits Simulation Practical	25	75	100	50	3
23065	Computer Aided Electrical Drawing	25	75	100	50	3
20002	Communication and Life Skill Practical #	25	75	100	50	3
Total		125	375	500	230	

* Common with ECE branch

common with ALL branches

VII SEMESTER

Subject Code	SUBJECT	EXAMINATION MARKS			Minimum for PASS	Duration of Exam
		Internal Assessment Marks	Board Exam Marks	Total Marks		
24052	Micro Controller *	25	75	100	40	3
23062	Electrical Estimation and Energy Auditing	25	75	100	40	3
	Elective Theory – I	25	75	100	40	3
24055	Micro Controller Practical *	25	75	100	50	3
	Elective Practical – I	25	75	100	50	3
Total		125	375	500	220	

* Common with ECE branch

ELECTIVE SUBJECTS			
Any one of the following theory subject with the corresponding practical may be selected as Elective-I			
Elective Theory – I		Elective Practical – I	
23071	Control of Electrical Machines	23074	Control of Electrical Machines Practical
23072	Programmable Logic Controller	23075	Programmable Logic Controller Practical
23073	Electrical Machine Design	23076	Electrical Machine Design Practical

VIII SEMESTER

Subject Code	SUBJECT	EXAMINATION MARKS			Minimum for PASS	Duration of Exam
		Internal Assessment Marks	Board Exam Marks	Total Marks		
23061	Power System - II	25	75	100	40	3
	Elective Theory – II	25	75	100	40	3
23064	Wiring and Winding Practical	25	75	100	50	3
	Elective Practical – II	25	75	100	50	3
23067	Project Work	25	75	100	50	3
Total		125	375	500	230	

ELECTIVE SUBJECTS			
Any one of the following theory subject with the corresponding practical may be selected as Elective-II			
Elective Theory – II		Elective Practical – II	
23081	Power Electronics	23084	Power Electronics Practical
23082	Bio-Medical Instrumentation	23085	Bio – Medical Instrumentation Practical
24682	Computer Hardware and Networks @	24684	Computer Hardware and Networks Practical @

@ Common with Information Technology

SCHEME OF THE EXAMINATION
Diploma in Electrical and Electronics Engineering (Sandwich Pattern) (2030)
L- SCHEME

III SEMESTER

Subject Code	SUBJECT	EXAMINATION MARKS			Minimum for PASS	Duration of Exam
		Internal Assessment Marks	Board Exam Marks	Total Marks		
23031	Electrical Circuit Theory	25	75	100	40	3
23032	Electrical Machines - I	25	75	100	40	3
24031	Electronic Devices and Circuits *	25	75	100	40	3
23042	Measurements and Instruments	25	75	100	40	3
23034	Electrical Circuits and Machines Practical	25	75	100	50	3
24034	Electronic Devices and Circuits Practical *	25	75	100	50	3
23036	Work Shop Practical	25	75	100	50	3
20001	Computer Applications Practical #	25	75	100	50	3
Total		200	600	800	360	

* Common with ECE branch
Common with ALL branches

IV SEMESTER

Subject Code	SUBJECT	EXAMINATION MARKS			Minimum for PASS	Duration of Exam
		Internal Assessment Marks	Board Exam Marks	Total Marks		
23041	Electrical Machines - II	25	75	100	40	3
23045	Electrical Machines and Instrumentation Practical	25	75	100	40	3
20002	Communication and Life Skill Practice #	25	75	100	40	3
23091	In plant Training	25	75	100	40	3

V SEMESTER

Subject Code	SUBJECT	EXAMINATION MARKS			Minimum for PASS	Duration of Exam
		Internal Assessment Marks	Board Exam Marks	Total Marks		
23051	Power System – I	25	75	100	40	3
24043	Digital Electronics *	25	75	100	40	3
23044	Transducers and Signal Conditioners	25	75	100	40	3
23053	Special Electrical Machines	25	75	100	40	3
	Elective Theory – I	25	75	100	40	3
23055	Electrical Circuits Simulation Practical	25	75	100	50	3
24055	Digital Electronics and Linear Integrated Circuits Practical *	25	75	100	50	3
	Elective Practical – I	25	75	100	50	3
Total		200	600	800	360	

* Common with ECE branch

ELECTIVE SUBJECTS

Any one of the following theory subject with the corresponding practical may be selected as Elective-I

Elective Theory – I		Elective Practical – I	
23071	Control of Electrical Machines	23074	Control of Electrical Machines Practical
23072	Programmable Logic Controller	23075	Programmable Logic Controller Practical
23073	Electrical Machine Design	23076	Electrical Machine Design Practical

VI SEMESTER

Subject Code	SUBJECT	EXAMINATION MARKS			Minimum for PASS	Duration of Exam
		Internal Assessment Marks	Board Exam Marks	Total Marks		
23061	Power System – II	25	75	100	40	3
23062	Electrical Estimation and Energy Auditing	25	75	100	40	3
24052	Micro Controller *	25	75	100	40	3
	Elective Theory – II	25	75	100	40	3
23064	Wiring and Winding Practical	25	75	100	50	3
24055	Micro Controller Practical *	25	75	100	50	3
23065	Computer Aided Electrical Drawing	25	75	100	50	3
	Elective Practical – II	25	75	100	50	3
Total		200	600	800	360	

* Common with ECE branch

ELECTIVE SUBJECTS

Any one of the following theory subject with the corresponding practical may be selected as Elective-II

Elective Theory – II		Elective Practical – II	
23081	Power Electronics	23084	Power Electronics Practical
23082	Bio-Medical Instrumentation	23085	Bio – Medical Instrumentation Practical
24682	Computer Hardware and Networks @	24684	Computer Hardware and Networks Practical @

@ Common with Information Technology

VII SEMESTER

Subject Code	SUBJECT	EXAMINATION MARKS			Minimum for PASS	Duration of Exam
		Internal Assessment Marks	Board Exam Marks	Total Marks		
23067	Project Work	25	75	100	50	3
23092	In Plant Training	25	75	100	50	3
Total		50	150	200	100	

DRAFT SYLLABUS

**Diploma in Electrical and Electronics Engineering
Alternative Subjects for the K-Scheme to the L-Scheme**

Subject Code	Subject	Subject Code	Subject
III SEMESTER		III SEMESTER	
13031	Electrical Circuit Theory	23031	Electrical Circuit Theory
13032	Electrical Machines - I	23032	Electrical Machines - I
14031	Electronic Devices and Circuits	24031	Electronic Devices and Circuits
13034	Electrical Circuits and Machines Practical	23034	Electrical Circuits and Machines Practical
14034	Electronic Devices and Circuits Practical	24034	Electronic Devices and Circuits Practical
13036	Work Shop Practical	23036	Work Shop Practical
IV Semester		IV Semester	
13041	Electrical Machines - II	23041	Electrical Machines - II
13042	Measurements and Instrumentation	23042	Measurements and Instruments
14041	Analog and Digital Electronics	24043	Digital Electronics
13045	Electrical Machines and Instrumentation Practical	23045	Electrical Machines and Instrumentation Practical
14044	Analog and Digital Electronics Practical	24045	Digital Electronics & Linear Integrated Circuits Practical
11011	English Communication Practical	20002	Communication and Life Skill Practice
V Semester		V Semester	
13051	Power System – I	23051	Power System – I
14051	Microprocessor and Micro Controller	24052	Micro Controller
Elective Theory – I		Elective Theory – I	
13071	Control of Electrical Machines	23071	Control of Electrical Machines
13072	Programmable Logic Controller	23072	Programmable Logic Controller
13073	Electrical Machine Design	23073	Electrical Machine Design
13054	Wiring and Winding Practical	23064	Wiring and Winding Practical (VI Semester)
14054	Micro Controller Practical	24055	Micro Controller Practical
Elective Practical – I		Elective Practical – I	
13074	Control of Electrical Machines Practical	23074	Control of Electrical Machines Practical
13075	Programmable Logic Controller Practical	23075	Programmable Logic Controller Practical
13076	Electrical Machine Design Practical	23076	Electrical Machine Design Practical

Subject Code	Subject	Subject Code	Subject
VI Semester		VI Semester	
13061	Power System – II	23061	Power System – II
13062	Electrical Estimation	23062	Electrical Estimation and Energy Auditing
Elective Theory – II		Elective Theory – II	
13081	Power Electronics	23081	Power Electronics
14061	Computer Hardware and Networking	24682	Computer Hardware and Networks
14033	“C” Programming and OOPS		No Alternate
23065	Computer Aided Electrical Drawing	23065	Computer Aided Electrical Drawing
Elective Practical – II		Elective Practical – II	
13084	Power Electronics Practical	23084	Power Electronics Practical
14064	Computer Hardware and Networking Practical	24684	Computer Hardware and Networks Practical
14036	“C” Programming and OOPS Practical		No Alternate
13066	Project Work, Entrepreneurship, Environment and Disaster Management	23067	Project Work

SYLLABUS FOR DIPLOMA IN ELECTRICAL AND ELECTRONICS ENGINEERING L-SCHEME

Course Name : Diploma in Electrical and Electronics Engineering
 Subject Code : **23031**
 Semester : III Semester
 Subject Title : **ELECTRICAL CIRCUIT THEORY**

TEACHING AND SCHEME OF EXAMINATION

No. of weeks per Semester : 16

Subject	Instruction		Examination		
	Hours / Week	Hours / Semester	Assessment marks		
			Internal	Board Examination	Total
Electrical Circuit Theory	5	80	25	75	100

TOPICS AND ALLOCATION OF TIME

UNIT	TOPIC	TIME (Hours)
I	Fundamentals of Electric Circuit	15
II	Network Theorems	13
III	Single phase A.C Series Circuits	14
IV	Single phase A.C Parallel Circuits and Resonant Circuits	13
V	Three Phase A.C. Circuits	13
	Revision and Test	12
	Total	80

RATIONALE

Understanding the current flow characteristics, various Laws and theorems dealing with Electric Circuits is very much essential to study a course in Electrical Engineering. This subject may be the introductory to the Electrical Engineering but without a strong knowledge in this subject one cannot understand the other subjects of Electrical Engineering. Based on this requirement, this subject is introduced in the Third Semester.

OBJECTIVES

To understand

- Electric field, Capacitance, Basic electricity, DC circuits and related laws.
- Network analysis, Basic theorems for dc circuits.
- Single phase ac fundamentals, RLC series circuits.
- Single phase ac parallel circuits and Resonance circuits.
- Three phase ac circuit fundamentals and three phase power measurement

**23031. ELECTRICAL CIRCUIT THEORY
DETAILED SYLLABUS**

Contents : Theory

Unit	Name of the Topic	Hours	Marks
I	<p>Fundamentals of Electric Circuit Basic concepts of current, emf, potential difference, power and energy – circuit elements – energy sources. Resistance - resistivity, temperature coefficient of resistance – Ohm's law – applications of Ohm's law - series circuits – voltage division – parallel circuits - current division – series and parallel circuits – Kirchoff's laws – Problems in the above topics. Inductance – self and mutual inductance. Electric Flux - Electric Flux Density – Electric field intensity – Electric potential – Coulomb's laws of electrostatics – concept of capacitance – relationship between Voltage, Charge and Capacitance – energy stored in a capacitor – capacitance of parallel plate capacitor – capacitors in series and in parallel – Problems in above topics.</p>	15	15
II	<p>Network Theorems Network – Branches – Nodes – Mesh current and Node voltage analysis – Voltage source and Current source transformations - Star and Delta transformations – Thevenin's Theorem - Norton's Theorem, Superposition Theorem and Maximum power transfer theorem. (Problems in D.C Circuits only)</p>	13	15
III	<p>Single phase A.C Series Circuits 'J' Operator – rectangular and polar coordinates – Sinusoidal voltage and current – instantaneous, peak, average and effective values – form factor and peak factor (derivations for sine wave) – pure resistive, inductive and capacitive circuits – RL, RC, RLC series circuits – impedance – phase angle – phasor diagram – power and power factor – power triangle – apparent power, active and reactive power – problems on all the above topics.</p>	14	15
IV	<p>Single phase A.C Parallel Circuits and Resonant Circuits</p> <p>a) Single phase A.C Parallel Circuits Parallel circuits (two branches only) – conductance, susceptance and admittance – problems.</p> <p>b) Resonant Circuits Resonance : Series resonance – Resonance Frequency – Resonance Curves – Variation of current and voltage distribution in series RLC circuit with frequency – Selectivity – 'Q' factor – Half power frequencies – Bandwidth. Parallel resonance – Two branch parallel circuits – Resonance frequency – Q Factor – problems.</p>	13	15

Unit	Name of the Topic	Hours	Marks
V	Three Phase A.C. Circuits Importance of 3 phase circuits – Star, Delta connections – Phase sequence – Balanced load – Relation between voltages, currents of line and phase values in star and delta connection – Problems in balanced loads of star and delta connections – Measurement of 3 phase power using two wattmeter method (Derivation and Problems) – Effects of unbalanced loads in Star and Delta systems	13	15

TEXT BOOK

Sl.No.	Name of the Book	Author	Publisher
1.	Electric Circuit Theory	Dr.M.Arumugam Dr.N.Premkumaran	Khanna Publishers, New elhi

REFERENCE BOOKS

Sl.No.	Name of the Book	Author	Publisher
1.	Circuits and Networks Analysis and Synthesis.	A. Sudhakar Shyammohan S Palli	Tata McGraw Hill Education Private Ltd.,
2.	Electric Circuits	Mahamood Nahvi Joseph A Edminister	Tata McGraw Hill Education Private Ltd.,

ELECTRICAL CIRCUIT THEORY
MODEL QUESTION PAPER I

Time: 3 hours

Marks: 75

Note: Part A questions carry each 1 mark and answer any Fifteen questions.

Part B questions carry each 12 marks and answer all questions by selecting either “a” or “b”.

PART-A

01. State Ohm's Law
02. State electric flux density.
03. Write the formula for capacitance of a parallel plate capacitor.
04. Define Self inductance.
05. What is a node?
06. Give the current equivalent of voltage source.
07. Write the expression for star to delta transformation
08. State the condition for maximum power transferred from source to load.
09. Define cycle
10. Convert $50 \angle 30$ into rectangular form.
11. Define form factor
12. Draw the vector diagram for RC series circuit.
13. Define admittance
14. State the condition for series resonance
15. Define dynamic resistance
16. Define 'Q' factor
17. Define balanced load in three phase system
18. Define phase sequence
19. State the relationship between line voltage and phase voltage in star connected system.
20. Write the expression for power factor when the power of a three phase circuit is measured by two wattmeter method

PART - B

1. a. Three resistors 12 ohm, 18 ohm and 36 ohm are connected in parallel. This parallel circuit is connected in series with a resistor 'R'. The whole circuit is connected is supplied at 60 Volt and it is found that power developed in 12 ohm resistor is 48 watts. Determine the value of R and total power. (12)

OR

- b. 1. A circuit consists of two resistors 20 ohm and 30 ohm connected in parallel. They connected in series with a resistor of 15 ohm. If the current through the 15 ohm resistor is 3 A, find the current in the other resistors and supply voltage. (6)

2. Show that $R_t = R_0 (1 + \alpha_0 t)$ (6)

22. a.1. Obtain Thevinin's equivalent circuit at terminals AB of the circuit given below. (6)

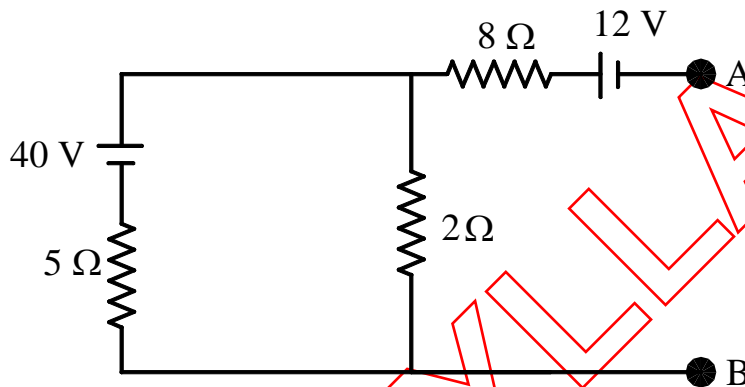

2. Reduce the given circuit into a single voltage source by using source transformation. (6)

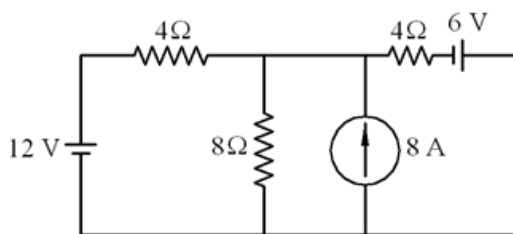

OR

- b. Find the power dissipated in the 10 Ω resistor using Node-Voltage method (12)

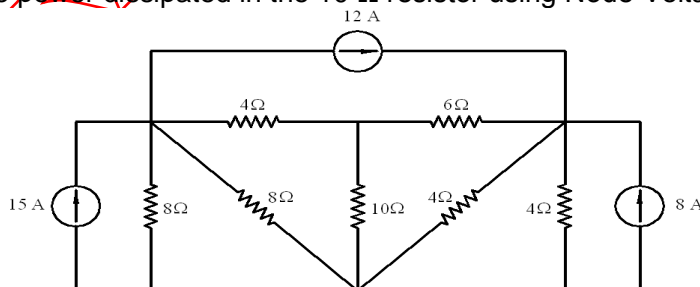

23. a. 1. The alternating current passing through a circuit is given by $141.4 \sin 314.2t$. Find the values of (a) r.m.s current, (b) the frequency (c) the instantaneous value of the current when $t=0.02$ second. (6)

2. From the fundamental principle show that the R.M.S. value of a sinusoidal alternating current is 0.707 times the maximum value. (6)

OR

b. A current of 5A flows through a non-inductive resistance in series with a choking coil when supplied at 250V, 50Hz. If the voltage across the resistance is 125V and across the coil 200V, calculate (a) the impedance, reactance and resistance of coil (b) the power absorbed by the coil and (c) the total power. Draw the vector diagram (12)

24. A circuit contains two impedances $Z_1 = (3 + j4)$ ohms and $Z_2 = (4 + j3)$ ohms in parallel and connected to 50V, 50 Hz supply. Determine the currents through impedances, total current, power and power factor. (12)

OR

b. A coil of 10 ohm and 0.4 henry is in series with a capacitor of 40 mfd. A voltage of 200 volt at variable frequency is applied to the circuit. At what frequency will the current be maximum? Also calculate current, voltage across the coil and capacitor at this frequency. (12)

25. a. 1. Derive the relation between the line and phase current in a delta connected circuit. (6)

2. A balance delta connected load of $(8+j6)$ ohms per phase is connected to a three phase 400V supply. Calculate the total power consumed. Also find out the readings of the two wattmeters connected to measure power. (6)

OR

b. A balanced load connected to a three phase supply comprises three identical coils in star. The line current is 25 A, KVA input is 20, KW input is 11. Find the phase voltage, line voltage, KVAR input, resistance and reactance of each coil of the load. (12)

ELECTRICAL CIRCUIT THEORY
MODEL QUESTION PAPER II

Time: 3 hours

Marks: 75

Note: Part A questions carry each 1 mark and answer any Fifteen questions.

Part B questions carry each 12 marks and answer all questions by selecting either "a" or "b".

PART - A

01. Define resistivity
02. Define Electric field.
03. Write the relationship between voltage, charge and capacitance.
04. State Kirchhoff's current law.
05. Define network.
06. Draw the Norton's equivalent circuit.
07. State the basis for node voltage analysis.
08. Write the expression for delta to star transformation
09. Define Amplitude
10. What is the equation for a sinusoidal current of 25 Hz frequency having a R.M.S. value of 40 amps?
11. Define power factor
12. State the relationship between voltage and current in a pure inductive circuit.
13. Define conductance.
14. Draw the admittance triangle.
15. Define bandwidth of RLC series resonance circuit.
16. State the condition for parallel resonance.
17. State the two types of three phase connections.
18. Write the expression for power in three phase system.
19. Write the relationship between line current and phase current in delta connected system.
20. Define unbalanced load in three phase system.

PART - B

- 21 a. A resistor of 10 ohm is connected in series with two resistors of 15 ohm arranged in parallel. What resistance must be shunted across the parallel combination so that the total current taken shall be 1.5A with 20V applied? (12)

OR

- b. 1. An aluminium wire has a resistance of 3.6 ohm at 20°C. What is its resistance at 50°C, if the temperature coefficient of resistance is 0.00403 at 20°C? (6)
2. Derive an expression for energy stored in a capacitor. (6)

- 22 a. By Mesh current method, determine the current in the 10 Ω resistor. (12)

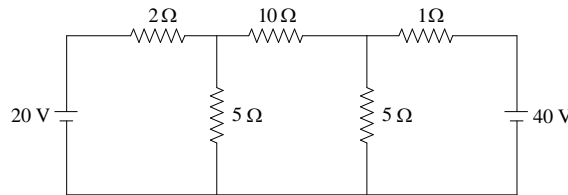

OR

- b. 1. Using Norton's theorem, find current through 6 ohm resistance. (6)

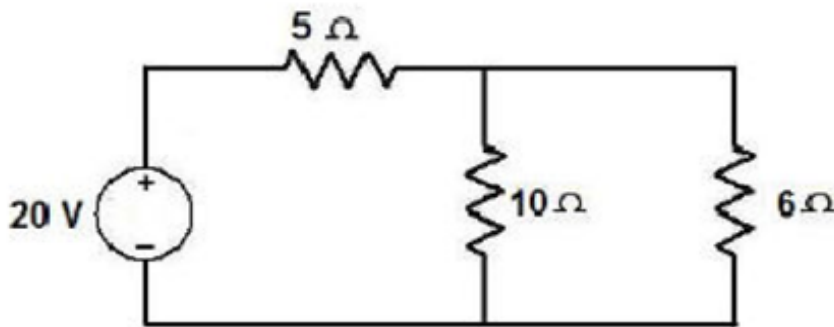

2. Determine the current through the 8 Ω resistor using superposition theorem. (6)

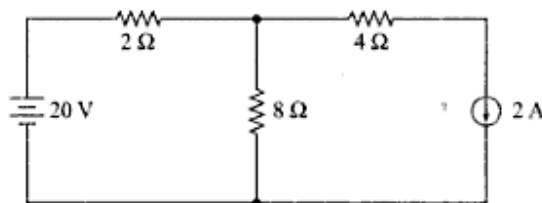

23. a. A circuit consists of a pure resistance and a coil in series. The power dissipated in the resistance is 500W and the drop across it is 100 V. The power dissipated in the coil is 100W and the drop across it is 50V. Find the reactance and resistance of the coil and the supply voltage. (12)

OR

b. Two coils A and B are connected in series across a 240V, 50 Hz supply. The resistance of A is 5 ohm and the inductance of B is 0.015H. If the input from the supply is 3KW and 2KVAR, find the inductance of A and resistance of B. (12)

24. a. A circuit consists of a 10 ohm resistor, a 300 mfd capacitor, an inductor having an inductance of 0.96H all in parallel across a 200V, 25Hz supply. Calculate (a) the current in each branch (b) the total current (c) the power factor of the complete circuit and (d) the total power. (12)

OR

b. An inductive circuit of resistance 2 ohm and inductance of 0.01 H is connected to a 250V, 50Hz supply. What capacitance placed in parallel will produce resonance? Also find the total current taken from the supply, Q factor and dynamic resistance. (12)

25. a. 1. Derive the relation between the line and phase voltage in a star connected circuit. (6)
2. List out the advantages of three phase system over single phase system. (6)

OR

b. With the aid of phasor diagram show that three phase power and power factor can be measured by using two watt meters. (12)

**STATE BOARD OF TECHNICAL EDUCATION AND TRAINING, TAMIL NADU
SYLLABUS FOR DIPLOMA IN ELECTRICAL AND ELECTRONICS ENGINEERING
L-SCHEME**

Course Name : Diploma in Electrical and Electronics Engineering
 Subject Code : **23032**
 Semester : III Semester
 Subject Title : Electrical Machines-I

TEACHING AND SCHEME OF EXAMINATION

No. of weeks per Semester : 16

Subject	Instruction		Examination		
	Hours / Week	Hours / Semester	Assessment marks		
			Internal	Board Examination	Total
Electrical Machines-I	5	80	25	75	100

TOPICS AND ALLOCATION OF TIME

UNIT	TOPIC	TIME (Hours)
I	ELECTRO MAGNETISM	13
II	DC GENERATORS	15
III	DC MOTORS	14
IV	SINGLE PHASE AND THREE PHASE TRANSFORMER	13
V	MAINTENANCE OF DC MACHINES AND BATTERIES	13
	REVISION AND TEST	12
	TOTAL	80

RATIONALE

Electrical machines play vital role in every aspect of our life. They generate Electricity. All the machineries in industries are driven by electrical motors. Therefore study of machines is must for any course in Electrical Engineering. In this subject DC machines, Transformers and Batteries are introduced.

OBJECTIVES

- ❖ Magnetic circuits and Principle, Magnetic Materials, Inductions and Associated laws
- ❖ DC Generator Principle, construction, types of windings, Types of Generators
- ❖ Characteristics, Testing, efficiency and applications
- ❖ DC Motor Principle, Construction, types of winding, Types of Motors
- ❖ Characteristics, Testing, efficiency and application and starters
- ❖ Principle of Transformer, Construction, EMF Equations, Vector diagrams, losses, Regulation, Efficiency, Auto transformer, Parallel operation and load sharing
- ❖ 3- Φ Transformer connections, parallel operation, protective devices, cooling methods and tap changing methods
- ❖ Maintenance of DC Machines, construction and active Materials of Acid and alkaline Batteries

23032 ELECTRICAL MACHINES-I DETAILED SYLLABUS

Contents : Theory

Unit	Name of the Topic	Hours	Marks
I	<p><u>ELECTRO MAGNETISM</u></p> <p>Introduction - Magnetism - Magnetic Materials -Magnetic Field- Magnetic Flux (Φ) - Laws of Magnetic Force (F) Magnetic field strength (H) - Flux Density (B) - [Intensity of Magnetisation (I)] - Absolute and Relative Permeability of a Medium - Force on a Current Carrying Conductor Lying in a Magnetic Field (Derivation) - Problems.</p> <p>Definition - Concerning Magnetic Circuit - MMF, Amphere Turns (AT) – Reluctance (R), Permeance (M), Reluctivity, Comparision B/W Magnetic and Electric Circuit - Problems in Magnetic Circuits - Magnetic Hystersis, Eddy Current Losses - Lifting Power of Electro Magnet and Energy Stored in Magnetic Field - Faraday's Law of Electromagnetic Induction - Len's Law - Fleming's Left Hand and Right Hand Rule - Induced EMF (E) - Self Induction - Mutual Induction - Statically, Dynamically Induced EMF.</p>	13	15
II	<p><u>DC-GENERATORS</u></p> <p>Introduction - Construction and Principle of DC Generators - Armature Windings - Important Terms about windings - Lap Winding and Wave Windings - Development of Winding Diagram for 24 Slots and 4 Poles Single Layer Lap & Wave Winding - Types of Generots - Condition for Self Excitation - EMF Equation - Problems - Losses - Power Stages - Efficiency - Problems - Characteristics of DC Generator - No Load Characteristic - Load Characteristic for DC Series, Shunt & Compound Generators - Armature Circuit Resistance - Armature Reaction - Compensation of Armature Reaction - Swinburne's Test - Load Test (DC Shunt, Series and Compound Generators) - Application of DC Generators.</p>	15	15

Unit	<u>Name of the Topic</u>	Hours	Marks
III	<p><u>DC-MOTORS</u></p> <p>Introduction - Construction and Principle of Operation of DC Motors - Significance of the Back EMF(E_b) - Voltage - Equation of a Motors - Types of Motors - Torque (Derivation) - Armature Torque - Shaft Torque - Problems - Speed of DC Motors - Torque - Speed Relationship - Losses & Efficiency - Comparison of DC Shunt & DC Series Motors - Power Stages - Critical Resistance and Critical Speed - Characteristics of DC Motor - Torque Vs Armature Current, Speed Vs Armature Current, Speed Vs Armature Torque for DC Motors - Speed Control Factors Controlling Motors Speed - Armature Control & Field Control for DC Motors - Load Test (DC Shunt, Series - Compound Motors) - Commutation - Methods of Improving Commutation - Application of DC Motors.</p> <p><u>DC STARTERS:</u></p> <p>Necessity of Starters – Construction and Working principles of 3 Point and 4 Point Starters</p>	14	15
IV	<p><u>SINGLE PHASE TRANSFORMER:</u></p> <p>Introduction - Working Principle - Construction - EMF Equation - Voltage Transformation Ratio - Transformer Rating - Problems - No Load Vector Diagram - Problems - Transformer on Load - Transformer With Resistance and Leakage Reactance - Vector Diagram on Load (Different Power Factors) - Equivalent Circuits - OC and SC Test - Regulation - Losses - Efficiency - Problems - Condition for Max Efficiency - All Day Efficiency - Auto Transformer - Principle and Advantages - Parallel Operation - Load Sharing.</p> <p><u>THREE PHASE TRANSFORMER:</u></p> <p>Construction - 3ϕ Transformer Connection - 3ϕ To 2 Phase Conversion - Parallel Operation - Cooling Methods - Protective Devices and Accessories (Conservator, Breather, Buchholz Relay & Explosion Vent) - Necessity of Tap Changers - on Load & off Load Tap Changers.</p>	13	15

Unit	Name of the Topic	Hours	Marks
V	<p><u>MAINTENANCE OF DC MACHINES:</u></p> <p>Causes of Sparking in Commutators - Defects in Commutator and Remedies - Resurfacing of Commutators and Brushes - Function & Requirements - Brush Holder – Formation & Different Types - Staggering of Brushes - Brush Pressure - Defects in Dc Armature Winding - Growler.</p> <p><u>STORAGE BATTERIES:</u></p> <p>Faraday's Law of Electrolysis - Primary and Secondary Batteries - Classification of Secondary Batteries Based on their uses.</p> <p><u>LEAD ACID BATTERY:</u> Construction, Active Materials and Chemical Chains - Electrical Characteristics of Lead Acid Cell, Battery Rating - Indication of fully Charged Cell - Application of Lead Acid Battery - Method of Charge System - Constant Current and Constant Voltage System - Trickle Charging - Maintenance of Lead Acid Cell.</p> <p><u>ALKALINE BATTERY:</u> Nickel Iron and Edison Batteries - Construction, Active Material and Chemical Changes - Electrical Characteristics - Comparison of Lead and Edison Cells.</p>	13	15

TEXT BOOK

Sl.No.	Name of the Book	Author	Publisher
1.	A Course in Electrical Engineering (Volume-2)	B.L.Theraja	S.Chand & Co. New Delhi
2.	Electrical Machines Theory and Practice	M.V. Desh Pande	PHI Learning New Delhi, 2011

REFERENCE BOOKS

Sl.No.	Name of the Book	Author	Publisher
1.	Electrical Machines Theory and Practice	M.N.Bandyopadhyay	PHI Learning New Delhi, 2011
2.	Operation & Maintenance Electrical Equipment (Volume 1 & Volume 2)	B.V.S. Rao	Media promoters & Publisher Private Limited, Bombay
3.	Electrical Technology	J.P.Gupta	S.K.Kataria & Sons New Delhi

MODEL QUESTION PAPER-I

PART-A

Answer any 15 questions out of 20 given questions. One mark for each question.

1. Define Magnetic flux (Φ)
2. State Laws of Magnetic Force (F)
3. State Fleming's Left Hand Rule
4. Explain Mutual Induction
5. What is Lap winding?
6. What is the condition for self excitation?
7. Draw the circuit for DC series Generator
8. State any two application of DC compound generator
9. Define Back emf.
10. Write the Torque equation of a DC Motor
11. Explain Critical Resistance
12. State any two applications for a DC series motor
13. Why transformer rating is always in KVA?
14. Draw No Load Vector Diagram of a Single Phase Transformer.
15. What is the condition for Maximum efficiency?
16. Write any two advantages of Parallel Operation
17. What is the use of Silica Gel in Bucholz relay?
18. Write any two causes of sparking in commutators.
19. Define Secondary Battery
20. What are the indications of fully charged cell for Lead Acid Battery?

PART-B

21. Write short notes on the following:

- A 1. Hysteresis Losses & Eddy Current Losses (6)
2. Explain statically Induced EMF with neat diagram (6)

(OR)

- B 1. Derive force on a current carrying conductor lying in a Magnetic field. (6)
2. Define Magnetic field strength (H), flux density (B), Intensity of Magnetization (I) (6)

22. A. 1. Drive EMF equation of a DC Generator (6)

2. A DC shunt Generator has the following data.

Load Current is 500A Rated Voltage is 450V
Shunt field resistance (R_{sh}) 120Ω Armature resistance is 0.030 ohms

- Find the Generated EMF. (6)
- (OR)
- B. 1. Explain Load Characteristics of a DC shunt Generator (6)
2. Explain the 3 components of a DC Machine (6)
- Field System Commutator Yoke
23. A. 1. Explain working principle of operation of DC Motor (6)
2. Develop the Torque equation of the DC Motor (6)
- (OR)
- B. 1. Explain commutation with neat diagram. (6)
2. Explain 3 point starter with neat diagram (6)
24. A.1. Explain working principle of Transformer (6)
2. Explain open circuit test with neat diagram (6)
- (OR)
- B.1. Write about any two 3 phase transformer connection (6)
2. Write short notes about Bucholz relay (6)
25. A.1. Write common causes of sparking in commutators (6)
2. Explain Staggering of Brushes (6)
- (OR)
- B.1. What are Maintenance of Lead Acid Cell (6)
2. Compare Lead Acid and Edison Cell (6)

MODEL QUESTION PAPER-II

PART-A

Answer any 15 questions out of 20 given questions. One mark for each question.

1. Define Absolute and relative permeability
2. Define Ampere Turn (A.T)
3. State Len's Law
4. Compare any two factors between Magnetic and Electric circuit
5. What is wave winding?
6. Explain separately excitation
7. Define Back pitch and Front pitch
8. What is an Armature?
9. Draw the Speed-Torque curve of a DC Motor
10. What are the Speed Control factors?
11. Draw the circuit diagram of a DC series Motor
12. Write any 2 application of DC Shunt Motor
13. Define Voltage transformation ratio
14. Define Regulation
15. What is Auto transformer?
16. What are the conditions for 2 single phase transformer parallel?
17. What is the function of Brush?
18. State Faraday's Law Electrolysis.
19. What is the active material used in Nickel – Iron cell?
20. What is specific gravity of H_2SO_4 ?

PART-B

21. A. Derive Lifting Power 'P' is equal to $\frac{B^2 A}{19.62 \mu^0}$ Kg.Wt.

by Neat Explanation.

(OR)

b) Explain dynamically induced emf.

22. a) Explain constructional details of a DC Generator

(OR)

b) Explain an Armature reaction with neat diagram

23. a) Explain Armature control and field control method

(OR)

b) Explain 4 point starter with a neat diagram

24. a) Explain Auto Transformer and also write advantages and disadvantages

(OR)

b) Write short notes on Load & Off Load Tap changes

25. a) Explain Growler with neat diagram

STATE BOARD OF TECHNICAL EDUCATION AND TRAINING, TAMIL NADU
SYLLABUS FOR DIPLOMA IN ELECTRICAL AND ELECTRONICS ENGINEERING
L-SCHEME

Course Name : Diploma in Electrical and Electronics Engineering
 Subject Code : **24031**
 Semester : III
 Subject Title : **Electronics Devices and Circuits**

TEACHING AND SCHEME OF EXAMINATION

No. of weeks per Semester : 16

Subject	Instruction		Examination		
	Hours / Week	Hours / Semester	Assessment marks		
			Internal	Board Examination	Total
Electronic Devices and Circuits	5	80	25	75	100

TOPICS AND ALLOCATION OF TIME

UNIT	TOPIC	TIME (Hours)
I	Semiconductor and Diodes	14
II	Bipolar Junction Transistor	14
III	Transistor oscillators and FET and UJT	15
IV	SCR, DIAC, TRIAC, MOSFET and IGBT	13
V	Opto Electronic Devices and Waveshaping Circuits	14
	Revision and test	10
	Total	80

RATIONALE

Electronics decides all controlling activities of Electrical machines. Study of various Electronic devices and the circuits incorporating these devices is very much essential. Therefore this subject is introduced. A thorough knowledge of this subject will be useful in understanding other subjects in Electronics.

OBJECTIVES

On completion of the following units of syllabus contents, the students must be able to:

- Study the working principle of PN junction diode and transistor
- Understand the working principle of different types of rectifiers
- Understand the different transistor configurations
- Differentiate various types of amplifiers
- Study the performance of special devices like UJT, FET
- Study the performance of different transistor oscillators
- Study the performance of SCR, DIAC, and TRIAC
- Study the performance of MOSFET and IGBT
- Know the construction and working principle of optoelectronic devices
- Study the performance of solar cell
- Explain the concept of wave shaping circuits
- Study the working principle of clippers and clampers

**24031 ELECTRONIC DEVICES AND CIRCUITS
DETAILED SYLLABUS**

Contents : Theory

Unit	Name of the Topic	Hours	Marks
I	<p>Semiconductor and Diodes:</p> <p>Semiconductor – Definition - classification of semiconductor - Intrinsic - Extrinsic semiconductor - N type & P type -Drift current & Diffusion current</p> <p>Diodes-PN junction diode-Forward and Reverse bias characteristics-Specification-Zener diode-Construction & working principle-Characteristics-Zener break down-Avalanche break down-Zener diode as a voltage regulator - Applications-Specifications</p> <p>Rectifier-Introduction-Classification of Rectifiers-Half wave rectifier-Fullwave rectifier- Bridge rectifier – Efficiency – Ripple factor – comparison - Applications – Filters – C, LC, and PI Filters.</p>	14	15
II	<p>Bipolar Junction Transistor:</p> <p>Transistor – NPN and PNP transistor – operation- Transistor as an amplifier – Transistor biasing – Fixed bias, Collector base bias, Self bias – CB, CE, CC Configurations – Characteristics – Comparison between three configurations in terms of input impedance, Output impedance, Current gain, Voltage gain – RC coupled amplifier – Load characteristic analysis – Emitter follower and its application – Negative feedback – Basic concept, effect of negative feedback, Types of Negative feedback connections – Transistor as a switch</p>	14	15
III	<p>Transistor Oscillators and FET and UJT</p> <p>Transistor- oscillator – Classifications – Condition for oscillations (Basrkhausen criterion) – General form of LC oscillator – Hartley Oscillator – Colpitts Oscillator – RC Phase shift oscillator, Crystal oscillator.</p> <p>Field Effect Transistor – Construction – Working principle of FET – Difference between FET and BJT – Characteristics of FET – Applications – FET amplifier(Common source amplifier).</p> <p>UJT – Construction – Equivalent circuit – Operation – Characteristics – UJT as a relaxation oscillator.</p>	15	15

Unit	Name of the Topic	Hours	Marks
IV	<p>SCR, TRIAC, DIAC, MOSFET and IGBT</p> <p>SCR – Introduction – Working – Two transistor analogy of SCR – VI Characteristics – SCR as a switch, Controlled rectifier – Specifications.</p> <p>TRIAC – Basic working principle – Characteristics – Speed control of fan using DIAC and TRIAC.</p> <p>DIAC – Construction – working – characteristics – DIAC as bi-directional switch.</p> <p>MOSFET – Construction – characteristics – MOSFET as a switch – CMOS basic concept.</p> <p>IGBT – Basic principle – IGBT as a switch.</p>	13	15
V	<p>Opto Electronics Devices and waveshaping circuits</p> <p>LDR, LED, 7 Segment LED, LCD, Opto coupler, Opto interrupter – Infrared transmitter and receiver - Laser diode(Simple treatment) – Solar cell – Avalanche Photo diode - Photo transistor.</p> <p>Diode clipper – Types – Clamper circuits using Diode – Voltage doubler, Astable, Monostable and Bistable operations using Transistor – Schmitt Trigger.</p>	14	15

TEXT BOOK

Sl.No.	Name of the Book	Author	Publisher
	Principle of Electronics	V.K.Mehta	S. Chand & Company Ltd.
1	Electronics Devices & Circuits	S.Sallaivahanan N.Suresh Kumar A.Vallavaraj	Tata McGraw Publication

REFERENCE BOOKS

Sl.No.	Name of the Book	Author	Publisher
1	Electronics principles	Malvino	Tata McGraw – Hill Publication
2	Electronics Devices & Circuits	Allen Mottershed	Tata McGraw – Hill Publication
3	Electronics Devices & Circuits	Jacob Millman and Halkies	Tata McGraw – Hill Publication
4	Optical Fiber Communication	Gerd Keiser	Tata McGraw – Hill Publication

24031 ELECTRONIC DEVICES AND CIRCUITS

MODEL QUESTION PAPER – I

Time : 3 Hrs.
PART A

Max Marks : 75
(15 x 1 = 15)

Answer any FIFTEEN questions

1. Give an example for donor impurity.
2. What is the cut in voltage for silicon diode?
3. What is the peak inverse voltage of full wave rectifier?
4. Name a component used for filtering.
5. Draw the symbol of NPN transistor.
6. What is the formula for current gain in common emitter configuration?
7. Which bias is normally used in applications?
8. What is the need for negative feedback?
9. What is the condition for oscillation?
10. What is the output frequency of Hartley oscillator?
11. Mention the relationship between the parameters of JFET.
12. State any two applications of UJT
13. Give an example for unidirectional switch.
14. Draw the symbol of TRIAC.
15. Name the terminals of DIAC.
16. Expand MOSFET.
17. In which bias, LED emits light?
18. Expand LASER.
19. What is the other name for Astable Multivibrator?
20. Draw the output waveform of negative clipper.

PART B

(5 x 12 = 60 Marks)

Note : i) Answer all Questions

ii) All sub divisions carry equal marks

- 21 A) Explain the operation of Zener diode and draw its characteristics.
B) Explain the operation of full wave rectifier and draw its output waveforms. List out its applications.
- 22 A) i) Explain the operation of NPN transistor.
ii) Compare three different configurations of transistors.
B) Explain the operation of RC coupled amplifier and draw its frequency response.
- 23 A) i) Explain the operation of Hartley oscillator.
ii) Differentiate FET with BJT
B) Explain the construction and operation of UJT.
- 24 A) i) Explain SCR as a controlled rectifier.
ii) Discuss about the specifications of SCR.
B) Explain the operation of DE-MOSFET with neat diagram.
- 25 A) Explain the operation of Solar cell and Photo Transistor.
B) Explain the operation of Schmitt Trigger and draw its output waveform.

-

24031 ELECTRONIC DEVICES AND CIRCUITS

MODEL QUESTION PAPER – II

Max Marks : 75

Time : 3 Hrs.

PART A

(15 x 1 = 15)

Answer any FIFTEEN questions

1. Give an example for intrinsic semiconductor.
2. Draw the symbol of Zener diode
3. What is the efficiency of half-wave rectifier?
4. How many filtering components are used in pi filter?
5. In which region transistor has to be operated for faithful amplification?
6. What is the output impedance of common base configuration?
7. What is Q-point?
8. Name the types of feedback
9. What are the components used in tank circuit?
10. State the advantages of crystal oscillator.
11. Give an example for voltage controlled device.
12. What is the formula for intrinsic standoff ratio?
13. What is the family name of SCR?
14. How many terminals are present in TRIAC?
15. Expand DIAC.
16. What are the types of MOSFET?
17. Draw the symbol of LDR.
18. What is solar cell?
19. Draw the output waveform of negative clamper.
20. How many stable states are present in Astable Multivibrator?

PART B

(5 x 12 = 60 Marks)

Note : i) Answer all Questions

ii) All sub divisions carry equal marks

- 21 A) Explain the operation and characteristics of PN junction diode with suitable diagram.
B) Explain the operation of C and pi filter and draw its waveform.
- 22 A) i) Explain the operation of transistor as an amplifier.
ii) Write short notes on fixed bias.
B) i) Explain the operation of emitter follower.
ii) Explain how transistor is used as a switch
- 23 A) i) Discuss about the conditions for oscillation..
ii) Explain the operation of RC phase shift oscillator.
B) Explain the working principle of JFET and draw its characteristics.
- 24 A) With neat diagram explain the working principle of SCR and draw the transistor analogy of SCR.
B) i) Explain the operation of DIAC with its characteristics.
ii) Explain the construction details of MOSFET.
25. A) Explain the operation of i) Opto interrupter ii) avalanche photo diode.
B) Explain the operation of positive and negative clamper.

**STATE BOARD OF TECHNICAL EDUCATION AND TRAINING, TAMIL NADU
SYLLABUS FOR DIPLOMA IN ELECTRICAL AND ELECTRONICS ENGINEERING
L-SCHEME**

Course Name : Diploma in Electrical and Electronics Engineering
 Subject Code : **23034**
 Semester : III
 Subject Title : **ELECTRICAL CIRCUITS AND MACHINES PRACTICAL**

TEACHING AND SCHEME OF EXAMINATION

No. of weeks per Semester : 16

Subject	Instruction		Examination		
	Hours / Week	Hours / Semester	Assessment marks		
			Internal	Board Examination	Total
ELECTRICAL CIRCUITS AND MACHINES PRACTICAL	6	96	25	75	100

RATIONALE

Diploma programme is a Technician Education and therefore skill development is an important component in the Diploma programmes. To impart practical knowledge to the diploma students, practical subjects are introduced for every corresponding theory subject. This subject is very much helpful in understanding circuit connections and study the characteristics of electrical machines.

OBJECTIVES

On completion of this practical subject, the students will be able to

- Make the various circuit connections
- Practically prove all the various laws and theorems dealing with current flow
- Understand the characteristics of electrical machines
- Test the transformer and machines and find out their characteristic
- Various speed control methods of electrical motors

23034 ELECTRICAL CIRCUITS AND MACHINES PRACTICAL

List of Experiments

- (1) Verification of Superposition Theorem with two different DC voltages for a common load
- (2) Verification of Thevenin's Theorem with DC supply
- (3) Measurement of Power by
 - (a) 3 Ammeter Method
 - (b) 3 Voltmeter Method
- (4) Verification of Maximum Power Transfer Theorem
- (5) Construct RLC Circuit for Series Resonance and draw the Frequency versus Impedance curve
- (6) Load Test on a single phase Transformer.
- (7) Load test on a Three-Phase Transformer.
- (8) Predetermination the efficiency and regulation of a single phase transformer by conducting OC and SC tests.
- (9) Find the equivalent circuit constants of a single phase transformer by conducting OC and SC tests.
- (10) Connect two single phase transformer for parallel operation by conducting Polarity test.
- (11) No Load and Load characteristics of self-excited DC shunt Generator
- (12) Load Characteristics of self-excited DC series Generator
- (13) Load Characteristics of separately excited DC shunt Generator
- (14) Load Test on DC shunt motor and draw the Performance Curves
- (15) Load Test on DC series motor and draw the performance curve
- (16) Predetermine the efficiency of DC machine by Swinburn's test.
- (17) Load Test on DC Compound Motor and draw the performance curve
- (18) Speed Control of DC shunt motor by
 - (a) Armature Control Method
 - (b) Field Control Method

ELECTRICAL CIRCUITS AND MACHINES PRACTICAL

Sl. No	LIST OF EQUIPMENTS	Quantity Required
1	Superposition theorem Trainer Kit	2
2	Thevenin's theorem Trainer Kit	2
3	Maximum power transfer theorem trainer Kit	2
4	RLC Series Resonance Trainer Kit	2
5	DC Shunt Motor 1 Hp with loading arrangement	1
6	DC Series Motor with loading arrangement	1
7	DC Compound Motor with loading arrangement	1
8	DC Shunt Generator with Terminal out let	1
9	DC Series Generator with Terminal outlet	1
10	1 phase Transformer 1KVA, 3KVA 220V/110V	3
11	3 phase Transformer 3KVA, 440V/220V	1
12	1 phase Variac Drum type	3
13	3 phase Variac Drum type	1
14	Loading Rheostat 230V,10A, 3 phase loading Rheostat	2
15	Loading Rheostat 230V,24A	1
16	Tachometer Analog type	2
17	Tachometer Digital	1
18	3 point starter	5
19	Rheostat – various ranges 50Ω-100Ω, 1300Ω-600Ω	10
20	DC Ammeter- various ranger 0-1,0-2,0-15,0-30	10
21	DC Voltmeter- various ranges 0-75V,0-150V, 0-300V,0-600V	10
22	AC ammeter-various ranges	5
23	AC Voltmeter- various ranges	5
24	Wattmeter-various ranges	5
25	4 point Starter	2

STATE BOARD OF TECHNICAL EDUCATION AND TRAINING, TAMIL NADU
SYLLABUS FOR DIPLOMA IN ELECTRICAL AND ELECTRONICS ENGINEERING
L-SCHEME

Course Name : Diploma in Electrical and Electronics Engineering
Subject Code : **24034**
Semester : III Semester
Subject Title : **ELECTRONIC DEVICES AND CIRCUITS PRACTICAL**

TEACHING AND SCHEME OF EXAMINATION

No. of weeks per Semester : 16

Subject	Instruction		Examination		
	Hours / Week	Hours / Semester	Assessment marks		
			Internal	Board Examination	Total
Electronic Devices and Circuits Practical	6	96	25	75	100

RATIONALE

Diploma programme is a Technician Education and therefore skill development is an important component in the Diploma programmes. To impart practical knowledge to the diploma students, practical subjects are introduced for every corresponding theory subject. This subject is very much helpful in understanding circuit connections and study the characteristics of electronic devices

OBJECTIVES

On completion of this practical subject, the students will be able to

- Make the various circuit connections involving electronic devices
- Understand the characteristics of electronic devices
- Test the performance characteristics of electronic devices
- Various amplifier, oscillator circuits

24034 ELECTRONIC DEVICES AND CIRCUITS PRACTICAL

Contents : Practical

List of Experiments

1. Identification and checking of passive and active components.
2. VI characteristics of PN junction diode.
3. VI characteristics of Zener diode.
4. Half wave and Full wave rectifier with and without filters
5. Bridge rectifier with and without filters.
6. VI characteristics of Regulator.
7. Input and output characteristics of CE configuration.
8. Frequency response of RC coupled amplifier
9. Frequency response of Emitter follower.
10. Negative feedback amplifier (any two)
11. RC phase shift oscillator.
12. Hartley and Colpitts oscillator.
13. JFET characteristics
14. Common source amplifier.
15. UJT characteristics.
16. UJT relaxation oscillator.
17. SCR characteristics
18. DIAC and TRIAC characteristics
19. Clipper, Clamper and voltage doublers.
20. LDR, Photo diode and photo transistor characteristics.
21. Solarcell and Opto coupler.
22. Astable and Monostable multivibrators using transistors.
23. Schmitt trigger using transistor.

Note: At least 10 experiments should be constructed using breadboard / soldering

EQUIPMENTS REQUIRED:

S.NO	Name of the Equipments	Range	Required Nos.
1.	Dual power supply	0-15V	10
2.	High Voltage Power Supply	0-250V	2
3.	Signal Generator	1MHz	10
4.	Dual trace CRO	20 MHz & 60 MHz	5 + 5
5.	Transformer	12-0-12V	5
6.	Digital Multi meter	-	10

Scheme of Evaluation

SI No.	Activity of the Candidate	Maximum Marks to be awarded
1	Drawing Correct Diagram and writing Details of the Components/Equipments/Machines used	15
2	Making the correct circuit connections	15
3	Conducting the Experiment - Following the correct procedure - Taking the appropriate readings - Following the appropriate safety procedure	25
4	Tabulation of Readings Interpretation of Results Graphical Representation (if required)	15
5	Viva-voce (Questions related to the given experiments only)	5
	Total Marks (External)	75

STATE BOARD OF TECHNICAL EDUCATION AND TRAINING, TAMIL NADU
SYLLABUS FOR DIPLOMA IN ELECTRICAL AND ELECTRONICS ENGINEERING
L-SCHEME

Course Name : Diploma in Electrical and Electronics Engineering
Subject Code : **23036**
Semester : V Semester
Subject Title : **WORKSHOP PRACTICAL**

TEACHING AND SCHEME OF EXAMINATION

No. of weeks per Semester : 16

Subject	Instruction		Examination		
	Hours / Week	Hours / Semester	Assessment marks		
			Internal	Board Examination	Total
WORKSHOP PRACTICAL	4	64	25	75	100

RATIONALE :

Every student must have some knowledge on various machining processes involved in the production. They must have tools-handling skills. To achieve these knowledge and skills a proper training in a workshop is essential and therefore this practical subject is introduced.

OBJECTIVES :

On completion of this practical training at workshop, the student shall possess the following skills

- Identify the tools required for various jobs
- To do simple turning, drilling, Knurling processes on a Lathe
- To make most common types of joints using a welding machine
- To know the functioning a Gas Welding Machine

23036 WORKSHOP PRACTICAL

DETAILED SYLLABUS

Content : Practical

Compulsory Exercises

I Lathe

Tools and Equipments

- 1) Plain turning
- 2) Step turning
- 3) Taper turning
- 4) Knurling
- 5) Drilling
- 6) Thread cutting

II Welding

Tools and Equipments

Making the following joints in MS flats of 6mm thick by arc welding

- 1) Lap joint
- 2) Butt joint
- 3) 'T' Fillet
- 4) 'L' Joint

Demonstration of Gas Welding



COMMON TO ALL BRANCHES

**L - SCHEME
2011 - 2012**

COMPUTER APPLICATIONS PRACTICAL

**DIRECTORATE OF TECHNICAL EDUCATION
GOVERNMENT OF TAMILNADU**

L-SCHEME
(Implements from the Academic year 2011-2012 onwards)

Course Name : COMMON TO ALL BRANCHES
 Subject Code : 20001
 Semester : III Semester
 Subject Title : COMPUTER APPLICATIONS PRACTICAL

TEACHING AND SCHEME OF EXAMINATION:

No of weeks per semester: 16 weeks

Subject Title	Instructions		Examination			Duration
	Hours /Week	Hours /Semester	Marks			
COMPUTER APPLICATIONS PRACTICAL	4 Hrs	64 Hrs	Internal Assessment	Board Examination	Total	3 Hrs
			25	75	100	

RATIONALE:

The application of Computer knowledge is essential to the students of all disciplines of Engineering in addition to their respective branch of study. The Computer Application Practical course facilitates the necessary knowledge and skills regarding creating, working and maintaining the documents, analyzing the data with charts manipulation of databases and presentation of documents with audio visual effects in a computer.

The learning of internet provides students with unprecedented opportunities to obtain information engage in discussion and liaise with individuals, organizations and groups world-wide. It provides the latest tools and technologies in helping the students to fetch better employment.

OBJECTIVES:

On completion of the following exercises, the students must be able to

- Understand the Windows operating systems
- Familiarize and customize the desktop
- Use the different facilities available in the word processor
- Analyze the data sheet
- Create and manipulate the database
- Prepare PowerPoint presentation
- Understand Internet concepts and usage of e-mail

GUIDELINES:

- All the eighteen experiments given in the list of experiments should be completed and all the experiments should included for the end semester practical examination.
- The end semester practical examination question paper contains two questions-the first question from section-I and the second question from section-II. Each question carries 35 marks and viva voce carries 5 marks.
- The computer systems should be 1:2 ratio for practical classes

ALLOCATION OF MARKS

1. Internal Assessment – 25 Marks

DESCRIPTION	MARKS ALLOTTED
Record with Printout	10
Assignment	5
Attendance	5
Model Examination	5
Total	25 MARKS

2. Board Examinations – 75 Marks

Content	Max. Marks	
	Section I	Section II
Writing steps	15	15
Execution of exercise	15	15
Result with Printout	5	5
Viva voce	5	
Total	75 Marks	

LAB EXERCISES

SECTION – I

WINDOWS

Introduction- History of Windows- screen saver and monitor resolution – Wallpaper setting- Folder manipulation – properties of a folder – Recycle bin – Short cuts – Sorting Folder – Switching between Application – Copying in CD/DVD settings – Recording Audio files.

Exercises

1.
 - a. Installing screen saver and change the monitor resolution by 1280X960
 - b. Setting wall papers
 - c. Creating, moving, deleting and renaming a folder
 - d. Copy, paste and cut a folder/file
 - e. Displaying the properties for a file or folder
2.
 - a. Restoring files and folders from Recycle bin
 - b. Creating short cuts for folder/file
 - c. Finding a file or folder by name
 - d. Selecting and moving two or more files/folders using mouse
 - e. Sorting folders/files.
3.
 - a. Copying files into CD/DVD
 - b. Switching between applications
 - c. Making the taskbar wider and hiding the taskbar
 - d. Recording and saving an audio file
 - e. Set/Change the date and time.

WORD PROCESSING

Introduction – Menus – Tool bar – Create – Edit – Save – Alignment – Font Size – Formatting – Tables – Fill Colors – Mail Merge – Page Setup - Preview – Water marking – Header – Footer – Clip art.

Exercises

4. Create the following table and perform the operations given below

ABC PVT. LTD.

Chennai

Production Summary of various Units in every Quarter

Unit	Product - ID	Jan-Mar	Apr-june	July-Sept.	Oct-Dec.
Unit - I	56	234.	50	74	125
Unit - II	142	236	126	175	251
Unit - III	213	541	216	60	43
Unit - IV	125	243	127	250	136
Unit - V	143	152	138	80	45

- Arrange Unit name as left align and other columns as right align.
 - Use doubled Border to the Summary Title and fill with 15% gray colour.
 - Implement merging and splitting two or more cells
 - Give alternative fore colour for columns.
 - Print the above table.
5. Create a standard covering letter and use mail merge to generate the customized letters for applying to a job in various organizations. Also, create a database and generate labels for the applying organizations.
6. Create a news letter of three pages with two columns text. The first page contains some formatting bullets and numbers. Set the document background colour and add 'confidential' as the watermark. Give the document a title which should be displayed in the header. The header/ footer of the first page should be different from other two pages. Also, add author name and date/ time in the header. The footer should have the page number.

SPREADSHEET

Introduction – Menus – Tool bar – Create – Edit – Save – Formatting cells – Chart wizard – Fill Colors –
Creating and using formulas – Sorting – Filtering.

Exercises

7. Create a result sheet containing Candidate's Register No., Name, Marks for six subjects. Calculate the total and result. The result must be calculated as below and failed candidates should be turned to red.
Result is Distinction if Total $\geq 70\%$
First Class if Total $\geq 60\%$ and $< 70\%$
Second Class if Total $\geq 50\%$ and $< 60\%$
Pass if Total $\geq 35\%$ and $< 50\%$
Fail otherwise
Create a separate table based on class by using auto filter feature.
8. Create a table of records with columns as Name and Donation Amount. Donation amount should be formatted with two decimal places. There should be at least twenty records in the table. Create a conditional format to highlight the highest donation with blue colour and lowest donation with red colour. The table should have a heading.
9. Prepare line, bar and pie chart to illustrate the subject wise performance of the class for any one semester.

SECTION – II

DATABASE

Introduction – Menus – Tool bar – Create – Edit – Save – Data types – Insert – Delete – Update – View –
Sorting and filtering – Queries – Report – Page setup – Print.

Exercises

10. Create Database to maintain at least 10 addresses of your class mates with the following constraints
 - Roll no. should be the primary key.
 - Name should be not null
11. Prepare a payroll for employee database of an organization with the following details:
Employee Id, Employee name, Date of Birth, Department and
Designation, Date of appointment, Basic pay, Dearness Allowance,
House Rent Allowance and other deductions if any.
Perform simple queries for different categories.
12. Design a pay slip for a particular employee from the above database.

PRESENTATION

Introduction – Menus – Tool bar – Create – Edit – Save – Slide transition – Insert image – Hyper link – Slide numbers – View slide show with sound – Photo album – Clip art.

Exercises

13. Make a marketing presentation of any consumer product with at least 10 slides. Use different customized animation effects on pictures and clip art on any four of the ten slides.
14. Create a Presentation on “Communication Skills” with three different slide transitions with sound effect.
15. Create a photo album in PowerPoint.

INTERNET

Introduction – Browsers – Open a website – Email: Send, receive and delete – Email with Attachments Google docs – Search Engines – Searching topics

Exercises

16. Create an e-mail id and perform the following
 - Write an e-mail inviting your friends to your Birthday Party.
 - Make your own signature and add it to the e-mail message.
 - Add a word attachment of the venue route
 - Send the e-mail to at least 5 of your friends.
17. Create a presentation on Google docs. Ask your friend to review it and comment on it. Use “Discussion” option for your discussions on the presentation.
18. Find out the direction and distance about road travel from Delhi to Agra using the Internet search. Also make a report of the Map and other details like place to stay and visit at Agra.

MODEL QUESTION PAPER

Year / Sem: II / III Subject: COMPUTER APPLICATIONS PRACTICAL Code: 2001	
Answer all the questions Max.Marks:75	
1	<u>Section - I</u> Prepare line, bar and pie chart to illustrate the subject wise performance of the class for any one semester.
2	<u>Section - II</u> Create an e-mail id and perform the following <ul style="list-style-type: none">• Write an e-mail inviting your friends to your Birthday Party.• Make your own signature and add it to the e-mail message.• Add a word attachment of the venue route• Send the e-mail to at least 5 of your friends.

LIST OF EQUIPMENTS AND THE QUANTITY REQUIRED FOR A BATCH OF 30 STUDENTS

SOFTWARE REQUIREMENTS	
Operating System	Windows XP or Windows Vista or Windows 7 / Linux
Office Package	Microsoft office 2000 or Office 2003 or Office 2007/Open Office
HARDWARE REQUIREMENTS	
Desktop Computer System with latest configuration	30 Nos
Power Backup (UPS)	10 KVA
Laser Printer	3 Nos

SAFETY PRECAUTIONS TO BE FOLLOWED BY STUDENTS

- Do not touch, connect or disconnect any plug or cable without teacher's permission
- Don't attempt to touch any live wires
- Systems should be shutdown properly after completion of work

REFERENCES

TITLE	AUTHOR	PUBLISHER	Year of Publication
Computer Applications Practical Manual	Dr.V.Karthikeyan Mr.D.Arulseivan	Learning Resource Centre, Thiagarajar Polytechnic College, Salem- 636 005	2012
Windows 7 in easy steps	Harshad kotecha	Tata McGrawHill	2011
A First Course in Computer 2003	Sanjay Sasena	Vikas Publications	2009
MS Office – 2003	Ramesh Bangia	Kanna Book Publication	2005
Introduction to Computers with MS-Office 2000	Alexis Leon & Mathews Leon	Tata McGraw-Hill	2002
Mastering Microsoft Office 2000	Gini Courter & Annette Marquis	BPB Publications	1999

STATE BOARD OF TECHNICAL EDUCATION AND TRAINING, TAMIL NADU
SYLLABUS FOR DIPLOMA IN ELECTRICAL AND ELECTRONICS ENGINEERING
L-SCHEME

Course Name : Diploma in Electrical and Electronics Engineering
 Subject Code : **23041**
 Semester : IV Semester
 Subject Title : Electrical Machines-II

TEACHING AND SCHEME OF EXAMINATION

No. of weeks per Semester : 16

Subject	Instruction		Examination		
	Hours / Week	Hours / Semester	Assessment marks		
			Internal	Board Examination	Total
Electrical Machines-II	5	80	25	75	100

TOPICS AND ALLOCATION OF TIME

UNIT	TOPIC	TIME (Hours)
I	ALTERNATORS	14
II	PERFORMANCE OF AN ALTERNATOR	13
III	THREE PHASE INDUCTION MOTOR	15
IV	SINGLE PHASE INDUCTION MOTOR AND SYNCHRONOUS MOTOR	13
V	MAINTENANCE OF AC MACHINES	13
	REVISION AND TEST	12
	TOTAL	80

RATIONALE

Electrical machines play vital role in every aspect of our life. They generate Electricity. All the machineries in industries are driven by electrical motors. Almost all the electrical drives used in the industries and domestic life are AC machines. Therefore study of AC machines is must for any course in Electrical Engineering..

OBJECTIVES

To understand

- ❖ Alternator Principle, Construction, Types, EMF Induced and cooling
- ❖ Performance of an Alternator, Testing, Characteristics, parallel operation, Load sharing etc.,
- ❖ 3- Φ Induction Motor, Principle, Construction, Types, Characteristics and Applications, starting Methods
- ❖ 1- Φ Motor types, Construction, Characteristics and Applications
- ❖ Synchronous Motor, Starting, Construction, Characteristics Applications
- ❖ Maintenance of A/C Machines, Induction Motor Maintenance, Transformer Maintenance, Transformer Earthing, Measurement of Earthing Resistance

**23041 ELECTRICAL MACHINES-II
DETAILED SYLLABUS**

Contents : Theory

Unit	Name of the Topic	Hours	Marks
I	<p>ALTERNATORS</p> <p>Basic Principle - Construction - Salient Pole Type and Cylindrical Type, Advantages Rotating Type (Stationary Armatur) - Damer Winding - Turbo Alternator - Types of Armature Winding - Terms Used In Armature Winding - Single Layer, Double Layer, Full Pitched, Fractional Pitched Winding, Slot Angle, Pitch Factor and Distribution Factor (Derivation) - Simple Problems.</p> <p>Effect of Pitch Factor on Harmonics – Advantages of Short Chorded Winding – Methods of obtaining Sine Wave in Salient Pole and Non-Salient Pole Alternators – EMF Equation – Problems – Cooling of Alternator – Different Methods – Advantages of Cooling by Using Hydrogen and its Merits – Alternator on Load.</p>	14	15
II	<p>PERFORMANCE OF AN ALTERNATOR</p> <p>Causes for Voltage Drop in Alternators – Armature Resistance – Armature Leakage Reactance – Armature Reaction – Synchronous Reactance – Vector Diagram of a Loaded Alternator – Voltage Regulation.</p> <p>OC and SC Test - Direct Load Test - Determination of Voltage regulation by Synchronous Impedence Method, Ampere Turn Method and Zero Power Factor Method -Problems on Synchronous Impedence Method and Ampere Turn Method - Load Characteristics of Alternators -Necessicity of Parallel Operation (Synchronizing) of Alternators - Dark Lamp Method - Bright Lamp Method - Synchroscope Method - Synchronizing Current -Synchronosing Power - Synchronising Torque - Effects of Changing Excitation of Alternators - Load Sharing of Two Alternators - Alternators Connected to Infinite Bus Bar.</p>	13	15

Unit	Name of the Topic	Hours	Marks
III	<p><u>THREE PHASE INDUCTION MOTOR:</u></p> <p>Introduction - Construction - Comparison of Cage and Slipring Induction Motor - Production of Rotating Magnetic Field in 3ϕ - Principle of operation - Slip - Frequency of Rotor Current - Torque - Starting Torque Derivation - Condition for Max Starting Torque - Rotor EMF and Reactance Under Running Condition - Torque Under Running Condition (Derivation) Problems - Slip Torque Characteristics - Relations B/W Starting Torque and Full Load Torque Development of Phasor Diagram - No Load & Block D Rotor Test - Development of Approximate Equivalent Circuit - Circle Diagram - Speed Control - Emf Method, Pole Changing Method, Rotor Resistance Method and Cading Method - Starters - DOL, Rotor Resistance Starter, Star Delta Starter, Auto Transformer Starter - Crawling and Cogging in Induction Motors - Applications.</p>	15	15
IV	<p><u>SINGLE PHASE INDUCTION MOTOR:</u></p> <p>Double Field Revolving Theory for Single Phase Induction Motor - Construction, Principle of Working and Application of Split Phase Motor, Capacitor Type Motors (Capacitor - Start and Capacitor Start and Run Motor) - Applications.</p> <p><u>SYNCHRONOUS MOTOR:</u></p> <p>Construction and Principle of Synchronous Motor - Why Syn.Motor is not Self Starting - Methods of Starting - Effects of Excitation on Armature Current and Power Factor - Comparison B/W Synchronous and Induction Motors - V Curve and Inverted Curve - Applications of Synchronous Motors.</p>	13	15
V	<p><u>MAINTENANCE OF AC MACHINES</u></p> <p><u>INDUCTION MOTORS:</u> Common Troubles and Their Remedies for Induction Motor Starters Single Phase Prevention Using Current Operations - Relay – Installation and Commissioning - Points to be Followed - Common Induction Motor Troubles and Their Remedies - Causes of Noise and Vibration - Care of Bearing - Static Balancing - Degreasing - Vacuum Impregnation - Varnishing - Drying out Process - Effect of Unbalanced Supply on the Performance of Induction Motor -</p>	6	15

	Periodical Maintenance - Points to be Remembered.		
--	---	--	--

V	<p>TRANSFORMERS: Preliminary Inspection - Inspection on Arrival and Before Installation - Measurement of Insulation Resistance - Drying out - Qualities of a Good Transformer Oil - Transformer Oil Tester - Methods of Oil Purification - Centrifugal Purifier - Stream Line Purifier - Metasil Filter - Acidity and Acidity Test - Dismantling Procedure for Distribution Transformer - Voltage Test, Continuity Test and Short Circuit Test on Distribution Transformer.</p> <p>Short Circuit Mechanical Forces - Importance of Bucholz Relay - Bucholz Relay Testing - Bucholz Relay Gas Analyser Construction - Gas Analysis by Colour of Gas by Using Gas Analyser - Common Transformer Troubles and their causes - Transformer Noise - Earthing - Measurement of Earth Resistance.</p>	7	
---	--	---	--

TEXT BOOK

Sl.No.	Name of the Book	Author	Publisher
1.	Electrical Machines	S.K.Batachariya	Tata Mc Grow Hill Publishing Company, New Delhi
2.	Operation & Maintenance Electrical Equipment (Volume 1 & Volume 2)	B.V.S. Rao	Media promoters & Publisher Private Limited, Bombay

REFERENCE BOOKS

Sl.No.	Name of the Book	Author	Publisher
1.	A Text Book of Electrical Technology	B.L. Theraja A.L. Theraja	S.Chand & Co. New Delhi
2.	Electrical Machines Theory and Practice	M.N.Bandyopadhyay	PHI Learning New Delhi, 2011
3.	Electrical Machines Theory and Practice	M.V. Desh Pande	PHI Learning New Delhi, 2011

MODEL QUESTION PAPER-I

PART-A

Answer any 15 questions out of 20 given questions. One mark for each question.

1. What type of rotor has been used in Turbo alternator?
2. Define fractional Pitched Winding
3. Write any two advantages of Short chorded winding
4. Define slot angle
5. Write the equation of voltage regulation
6. Define synchronous reactance
7. Draw the Load characteristic of an alternator
8. On what condition the switch should be closed by Dark lamp method?
9. What are the types of rotor?
10. What is the use of circle diagram?
11. What are different types of speed control in 3 phase induction motor?
12. Write the Slip Equation
13. What is the name used in the motor having the lowest rating than 1 HP?
14. Write any two applications of split phase induction motor
15. What is the principle of synchronous motor?
16. Write any two methods of starting of synchronous motor
17. What are common troubles in Induction Motor?
18. What are the types of Balancing?
19. Which instrument is used to measure the insulation resistance?
20. What is the B.D.V. value of good transformer oil?

PART-B

5X12=60

21. a) Derive the EMF Equation of an Alternator

(OR)

b) What are the advantages of Hydrogen cooling method

22. a) Draw neat circuit diagram and briefly explain open circuit and short circuit test.

(OR)

b) An alternator has the following data

- | | |
|---------------------------------|--|
| 1. Number of phases is 3 | 2. Number of slots on the Armature is 90 |
| 3. Number of poles is 10 | 4. Number of conductor per slot is 8 |
| 5. Distribution factor is 0.965 | 6. full pitched winding |
| 7. flux per pole is 0.040 wb | 8. speed of alternator is 600 rpm |
| 9. Connection is star | |

Determine No Load Terminal Voltage

23. a) Compare squirrel case and slip ring Induction Motor

(OR)

b) Explain No load and Blocked rotor test

24. a) Explain principle of working Split Phase Induction Motor

(OR)

b) Explain effect of excitation on armature current and power factor

25. a) What are the causes of noise and vibration of an Induction Motor

(OR)

b) Explain any one method of Oil Purification

ELECTRICAL MACHINES-II
MODEL QUESTION PAPER-II

PART-A

Answer any 15 questions out of 20 given questions. One mark for each question.

1. Explain the term Double layer
2. Calculate the distribution factor for 48 slots 4 pole single layer 3 phase winding
3. Define Pitch factor
4. Write the EMF equation of an alternator
5. Write any two causes for voltage drop in alternator
6. What are the types to find voltage regulation in alternator?
7. What are the conditions for parallel operation of two alternators?
8. What is armature leakage reactance?
9. Draw the Slip-Torque characteristic curve
10. Which type of lamination is done by core in squirrel cage rotor?
11. What is the use of pole changing method?
12. Write any two applications of Induction Motor
13. What are the two types winding used in single phase motor?
14. What is the use of centrifugal switch?
15. Which type of Motor is used in Drilling Machine?
16. Write application of synchronous motor
17. Define single phasing
18. State any two installation procedure when an induction motor is installed.
19. What is mean by voltage test?
20. Define earthing

PART-B

5X12=60

21. a) Explain the constructional details of stator and rotor of a salient pole Alternator.

(OR)

- b) Explain the methods adopted to obtain sine wave shape of emf induced in the alternator.

22. a) Explain Armature reaction of an Alternator

(OR)

- b) Briefly explain effect of change in excitation

23. a) Explain Rotating Magnetic Field produced by 3 phase 2 pole system

(OR)

- b) Explain Rotor Resistance starter with a neat diagram

24. a) Explain capacitor Start and Run Motor with a neat diagram

(OR)

- b) Explain 'V' Curve and Inverted 'V' curve

25. a) Explain continuity test and short circuit on distribution Transformer

(OR)

- b) Explain Transformer Earthing and Measurement of Earth Resistance

STATE BOARD OF TECHNICAL EDUCATION AND TRAINING, TAMIL NADU
SYLLABUS FOR DIPLOMA IN ELECTRICAL AND ELECTRONICS ENGINEERING
L-SCHEME

Course Name : Diploma in Electrical and Electronics Engineering
 Subject Code : **23042**
 Semester : IV Semester
 Subject Title : **MEASUREMENTS AND INSTRUMENTS**

TEACHING AND SCHEME OF EXAMINATION

No. of weeks per Semester : 16

Subject	Instruction		Examination		
	Hours / Week	Hours / Semester	Assessment marks		
			Internal	Board Examination	Total
Measurement and Instruments	5	80	25	75	100

TOPICS AND ALLOCATION OF TIME

UNIT	TOPIC	TIME (Hours)
I	Classification and Characteristics of Instruments	15
II	Measurement of current Voltage and Resistance	15
III	Measurement of Power and Energy	12
IV	Measurement of Power factor Frequency and Phase difference	13
V	Measurement of L,C and waveforms	13
	Revision and Test	12
	Total	80

RATIONALE

Measurement is the basic and Primary operation, the result of which is used only to describe the system and hence treated as an independent operation. Automation of any kind begins with the measurement of certain system parameters; In fact, industrial growth moves hand in hand with the growth of the measurement of Science and technology. Therefore it is highly essential for Electrical students to study about the measurement of various electrical parameters in a system and the construction and working of different instruments used in measurement of such parameters.

OBJECTIVES

- To Define basic measurement terms.
- To learn about various operating forces and effects used in instruments.
- To study the construction and working of Moving coil and Moving Iron instruments, CT and PT, and electrostatic voltmeter.
- To understand the measurement of resistance. using different means.
- To study Single phase and Three phase power measurement using wattmeter.
- To study the construction and working of single phase, three phase energy meter and study about calibration
- To study the construction and working of Power factor meters, and phase sequence indicators.
- To study about the frequency measurement using different types of frequency meters.
- To learn about the measurement of inductance and capacitance using bridges.
- To study about CRO and it's applications.

**23042 MEASUREMENTS AND INSTRUMENTS
DETAILED SYLLABUS**

Contents : Theory

Unit	Name of the Topic	Hours	Marks
I	<p><u>Classification and Characteristics of Instruments</u></p> <p>General - Definition of Measurement – functions of Measurement system (Indicating, Recording and controlling function) – Applications of measurement systems – classification – Absolute and secondary instruments – Indicating Recording and Integrating Instruments – Analog and Digital – Definition of True value, accuracy, precision, error and error correction – Instrument efficiency – Effects used in instruments – operating forces – Deflecting, controlling and damping forces – constructional details of moving system – Types of Supports – Balancing – Torque weight ratio – control system (spring control and gravity control) Damping systems – Magnets – pointers and scales.</p>	15	15
II	<p>MEASUREMENT OF CURRENT, VOLTAGE AND RESISTANCE</p> <p>Types of Instruments – construction, working and torque equation of moving coil, Moving iron, dynamometer type (Shaded pole) Instruments – Extension of instrument range using shunts and multipliers. (calculation, requirements and simple problems). Tong tester – Electrostatic voltmeter – Rectifertype instruments – Instruments transformers CT and PT – Testing of CT and PT. Errors in CT and PT – characteristics of CT and PT - Classification of Resistance – measurement using conventional method – (Ammeter – voltmeter method) Measurement of low resistance using Kelvin's Bridge ohmmeter – measurement of Medium resistance using Wheatstone bridge – High resistance using Meggar - earth resistance – using Earth tester – Multimeters.</p>	15	15
III	<p>MEASUREMENT OF POWER AND ENERGY</p> <p>Power in D.C and A.C Circuits – watt meters in power measurement – Electrodynamometer type and LPF watt meters – Three phase power measurement using Three phase wattmeter.</p> <p>Measurement of Energy in AC circuits – Single phase and Three phase energy meters construction and operation – Errors and Error correction – Digital Energy meter – calibration using RSS meter. and working.</p>	12	15

Unit	Name of the Topic	Hours	Marks
IV	<p>MEASUREMENT OF POWER FACTOR, FREQUENCY AND PHASE DIFFERENCE</p> <p>Power factor meters – single phase and Three phase Electro dynamometer type – construction and working – phase sequence Indicator – phase difference measurement using synchroscope – Trivector meter – Merz price maximum demand Indicator.</p> <p>Frequency measurement – Frequency meter – Weston type – Digital Frequency meter – (Simplified Block diagram)</p>	13	15
V	<p>MEASUREMENT OF L,C AND WAVEFORMS</p> <p>Measurement of Inductance – Maxwell's Inductance bridge – Andersons bridge – Measurement of capacitance using Schering bridge.</p> <p>CRO – Block diagram – CRT – Applications - Measurements of voltage, frequency and phase difference using CRO - Time base and synchronization – Dural trace CRO – Digital storage oscilloscope – Block diagram</p>	13	15

TEXT BOOK

Title	Author(S)	Publishers	Edition
A Course in Electrical and Electronics Measurements and Instrumentation	1. A.K. Sawhney 2. Puneet Sawhney	Dhanpat Rai & Co (P) Ltd., New Delhi	1993

REFERENCE BOOKS

S. N	Title	Author(S)	Publishers	Edition
1.	Electronic Instrumentation	HS Kalsi	Tata Mc Graw Hill Publishing Co., Delhi	2010
2.	Modern Electronic Instrumentation and Measurement techniques	Albert D. Helfrick William David Cooper	Prentic – Hall of India (P) Ltd., New Delhi	2010
3.	Electronics and Instrumentation	Dr. S.K. Battachariya 1. Dr. Renu Vig	S.K. Kataria & Sons, New Delhi 6.	
4.	A course in Electrical and Electronic Measurement and Instrumentation	Umesh Sinha	Satya Prakashan, New Delhi	

MODEL QUESTION - I

Time – Three hours

(Maximum Marks : 75)

[N.B – 1. Answer any 15 questions from Part A Each Question carries 1 mark.

2. Answer all questions in part B choosing either (A) OR (B) in each Questions (OR) choosing either (A) (B) (OR) (C D) in each questions : Each Question in part B carries 12 Marks.

PART – A

15 X 1 = 15

1. Define Accuracy.
2. Mention the functions of measurement system.
3. What are the two essential requirements of moving systems?
4. Define error.
5. What are the two types of MI instruments?
6. State the use of tong tester.
7. Write the formula to find shunt resistance .
8. State the uses of multi meter.
9. What is meant by creep?
10. Differentiate power and energy.
11. Write the formula to find power in DC circuit and A.C circuit.
12. What is RSS meter?
13. What is maximum demand indicator?
14. What are the three quantities measured by Trivector meter?
15. Write the use of synchroscope.
16. List the types of power factor meters.
17. Name the bridge used for measurement of inductance.
18. What is time base as referred to CRO?
19. Name the fluorescent materials used in CRO screen.
20. List any two applications of CRO.

PART – B

- 21 (A).1 Explain spring control used in Instruments. (6)
2 Explain Eddy current damping in Instruments with neat sketches. (6)
(or)
- (B).1 List various effects used in Instruments explain any one. (6)
2. Explain three operating forces in Instruments. (6)
- 22 (A). Explain the construction and working of moving coil instruments (PMMC Type) with neat sketch. Derive Torque equation. (12)
(or)
- (B) Explain with neat sketch the construction and working of Megger state it's uses. (12)
- 23 (A) Draw and explain the construction and operation of Electro dynamometer type Wattmeter (12)
(B) Draw and explain the block diagram of Digital energy meter (12)
- 24 (A) Explain the working of Merz Price MDI with neat diagram. (12)
(or)
- (B) Explain the operation of Weston type frequency meter with neat diagram. (12)
- 25 (A) 1. Show how inductance is measured using Anderson's bridge (6)
2. Draw the block diagram of CRO and explain (6)
(or)
- (B) 1. Show how unknown capacitance is measured using Schering bridge (6)
2. Draw the block diagram of Digital storage oscilloscope and explain (6)

MODEL QUESTION - II

Time – Three hours

(Maximum Marks : 75)

[N.B – 1. Answer any 15 questions from Part A Each Question carries 1 mark.

2. Answer all questions in part B choosing either (A) OR (B) in each Questions (OR) choosing either (A) (B) (OR) (C D) in each questions : Each Question in part B carries 12 Marks.

PART – A

15 X 1 = 15

1. Define True Value.
2. Define Instrument efficiency.
3. List three types of operating forces.
4. List the types of supports.
5. State the use of shunts.
6. Write the formula to find multiplier resistance.
7. Name the instrument used for measuring high resistance.
8. What are the errors in CT and PT?
9. How creep is overcome in energy meter?
10. State the unit of power and energy.
11. List the four Mechanizing in AC energy meter?
12. What is the purpose of lagplate in energy meter?
13. What is phase sequence indicator?
14. What are the three quantities measured by Trivector meter?
15. List the types of frequency meter.
16. What are the sources of synchronization?
17. Name the bridge used for the measurement of capacitance.
18. What are the applications of CRO?
19. Name the fluorescent material used in CRO screen.
20. State the difference between Dual trace CRO and ordinary CRO.

PART B

- 21 (A) Explain Airfriction damping and Fluid friction damping (12)
(or)
(B) Explain spring control and gravity control (12)
- 22 (A) With neat sketch explain the construction and operation of Attraction type MI (12)
(or)
(B) With neat sketch explain the construction and working of Earth tester.
- 23 (A) With neat circuit explain the operation of single phase energy meter (12)
(or)
(B) With neat sketch explain the working of LPF wattmeter (12)
- 24 (A) With neat sketch explain the construction and operation of power factor meter. (12)
(or)
(B) Draw the block diagram of Digital frequency meter and explain. (12)
- 25 (A) 1. Draw and explain the working of CRT (6)
2. Draw the circuit of Schering bridge and write the formula to find unknown capacitance (6)
(or)
(B).1.Draw the block diagram of Dual trace CRO and explain (6)
2. Draw the circuit of Anderson bridge and write the formula to find unknown inductance. (6)

STATE BOARD OF TECHNICAL EDUCATION AND TRAINING, TAMIL NADU
SYLLABUS FOR DIPLOMA IN ELECTRICAL AND ELECTRONICS ENGINEERING
L-SCHEME

Course Name : Diploma in Electrical and Electronics Engineering
 Subject Code : **24043**
 Semester : IV Semester
 Subject Title : **Digital Electronics**

TEACHING AND SCHEME OF EXAMINATION

No. of weeks per Semester : 16

Subject	Instruction		Examination		
	Hours / Week	Hours / Semester	Assessment marks		
			Internal	Board Examination	Total
Digital Electronics	5	80	25	75	100

TOPICS AND ALLOCATION OF TIME

UNIT	TOPIC	TIME (Hours)
I	Number System, Boolean Algebra, Logic Gates and Digital Logic Families	14
II	Combinational Logic	14
III	Sequential Logic	14
IV	Memory Devices	13
V	Microprocessor - 8085	13
	Revision - Test	12
	TOTAL	80

RATIONALE

Today's world is of Digital Electronics. Digital concept is fast and very much accurate compared with analog systems. Study of Electronics means study of Digital Electronics. All the control, computing and measurement activities are made of Digital Electronics. This subject is introduced to impart a fair knowledge of digital circuits and systems.

OBJECTIVES

- To understand various Number System.
- To understand basic Boolean postulates and laws.
- To understand the De-Morgan's theorem.
- To understand the concept of Karnaugh Map.
- To Learn about logic Gates.
- To Study about Boolean techniques.
- To learn the different digital logic families
- To learn arithmetic circuits-adder/subtractor, BCD adder.
- To understand the encoder/decoder & MUX / DEMUX
- To understand the concept of parity Generator, and checkers
- To understand various types of flip-flops.
- To understand various types of counters.
- To understand various modes of shift registers.
- To understand the concept of RAM & ROM and its types.
- To understand the history and need of Microprocessor.
- To understand the internal architecture details of 8085 Microprocessor.
- To know the instruction set of 8085.
- To draw the timing diagrams for typical instructions
- To understand Interrupt Structure of 8085

**24043 DIGITAL ELECTRONICS
DETAILED SYLLABUS**

Contents : Theory

Unit	Name of the Topic	Hours	Marks
I	<p>NUMBER SYSTEM AND BOOLEAN ALGEBRA</p> <p>Binary, Octal, Decimal, Hexadecimal - Conversion from one to another. Binary codes – BCD code, Gray code, Excess 3code. Boolean Algebra – Boolean postulates and laws. De-Morgan's theorem, Simplification of Boolean expressions using Karnaugh map (up to 4-variables-pairs, quad, octets) - Don't care conditions and constructing the logic circuits for the Boolean expressions</p> <p>LOGIC GATES AND DIGITAL LOGIC FAMILIES: GATES – AND, OR, NOT, NAND, NOR, EX-OR, EX-NOR. Implementation of logic functions using gates, Realization of gates using universal gates. Simplification of expression using Boolean techniques, Boolean expression for outputs. Digital logic families – TTL, CMOS, Logics and their characteristics, comparison and applications, Tristate gate.</p>	14	15
II	<p><u>COMBINATIONAL CIRCUITS:</u></p> <p>Arithmetic circuits. Binary – Addition, subtraction, 1's and 2's complement. Signed binary numbers, Half Adder and Full Adder/ half Subtractor and Full Subtractor. Encoder, Decoder- 3 to 8 decoder, BCD to seven segment decoder. Multiplexer/Demultiplexer. BCD adder, parity checker and generator.</p> <p>– Interrupts (types & Priorities).</p>	14	15
III	<p><u>SEQUENTIAL CIRCUITS</u></p> <p>FLIP-FLOPS – SR, JK, T, D, JK- MS FF, Triggering of FF – edge & level. COUNTERS – Asynchronous/ripple counter, Decade counter, mod3, mod7 counter, Up – Down counter (4 bit), Synchronous counter, Johnson counter, Ring counter, Single digit BCD counter. REGISTERS - 4-bit shift register- Serial IN Serial OUT, Serial IN parallel OUT, Parallel IN Serial OUT, Parallel IN Parallel OUT.</p>	14	15

Unit	Name of the Topic	Hours	Marks
IV	MEMORY DEVICES Classification of memories, RAM organization - Address Lines and Memory Size, Read/write operations, Static RAM - Bipolar RAM cell, Dynamic RAM, SD RAM, DDR RAM. Read only memory – ROM organization, Expanding memory, PROM, EPROM, and EEPROM. Flash memory.	13	15
V	MICROPROCESSOR – 8085 Evolution of microprocessor, 8085 – Architecture, Instruction sets, Addressing modes, memory mapped I/O and I/O mapped I/O and its Comparison, Machine cycle – Opcode fetch, memory read, memory write, I/O read, I/O write. Instruction cycle (Timing diagram) for LDA, MOV r1, r2 instructions	13	15

TEXT BOOK

Sl.No.	Name of the Book	Author	Publisher
1	Principles of digital electronics	K.Meena	PHI – 2011
2	Microprocessor architecture, programming and application	Ramesh S. Gaonkar –	Wiley eastern limited.

REFERENCE BOOKS

Sl.No.	Name of the Book	Author	Publisher
1	Digital principles & Applications	Albert Paul Malvino & Donald P. Leach –	TMH.
2	Digital Electronics	William H. Gothmann –.	Prentice Hall of India
3	Modern Digital Electronics	R.P. Jain – TMH. Roger L. Tokheim Macmillan	McGraw – Hill – 1994.
4	Introduction to Microprocessor	ADITYA P MATHUR	Tata- McGraw-Hill publishing Company Limited

**STATE BOARD OF TECHNICAL EDUCATION AND TRAINING, TAMIL NADU
SYLLABUS FOR DIPLOMA IN ELECTRICAL AND ELECTRONICS ENGINEERING
L-SCHEME**

Course Name : Diploma in Electrical and Electronics Engineering
 Subject Code : **23044**
 Semester : IV Semester
 Subject Title : **TRANSDUCERS AND SIGNAL CONDITIONERS**

TEACHING AND SCHEME OF EXAMINATION

No. of weeks per Semester : 16

Subject	Instruction		Examination		
	Hours / Week	Hours / Semester	Assessment marks		
			Internal	Board Examination	Total
Transducers and Signal conditioners	4	64	25	75	100

TOPICS AND ALLOCATION OF TIME

UNIT	TOPIC	TIME (Hours)
I	Classification and Sensing elements	10
II	Passive Transducers	10
III	Active Transducers	10
IV	Operational amplifiers.	11
V	Signal conditioners in Industrial Instrumentation	11
	Revision and Test	12
	Total	64

RATIONALE

Sensors and transducers are used in automation in construction, domestic appliances industries, transport, space exploration, defence equipment, health services and other applications. Transducers have achieved substantial accuracy and control in Industrial automation, Transducers lie at the heart of instrumentation; Hence it becomes imperative to study about the principles and applications of various types of transducers in a single volume in Diploma level.

OBJECTIVES

- To understand the necessity and advantages of transducer.
- To learn about different types of transducers.
- To study the principle of working of resistive type passive transducers and its applications.
- To learn the operation and applications of capacitive and inductive transducer.
- To learn about various active transducers and their applications.
- To understand the concept of Digital encoding transducers.
- To know the concept of signal conditioning using op.amp
- To study the characteristics and various applications of op.amp.
- To understand the use of signal conditioners in Instrumentation.
- To learn about the selected applications of op.amp in Industrial Instrumentation.

23044 TRANSDUERS AND SIGNAL CONDITIONERS
DETAILED SYLLABUS

Contents : Theory

Unit	Name of the Topic	Hours	Marks
I	<p>CLASSIFICATION AND SENSING ELEMENTS</p> <p>General – Definition - Necessity - Types - classification based on the principle of operation - Active and passive - Primary and Secondary - Examples in each - Advantages - Primary sensing elements - Bourden tubes. Bellows – Load cells – Thermistors – Types – construction and operation of Metal Resistance thermometer – Digital encoding transducer.</p>	10	15
II	<p>Passive Transducers</p> <p>Resistive Transducer - Strain Gauge - construction and working of Strain gauge - Strain gauge in measurement of displacement - Capacitive transducer and its applications – Liquid level measurement using capacitive transducers - Inductive transducer - Basic structure - proximity sensor - Measurement of pressure using inductive transducer - Construction and operation of LVDT, RVDT.</p>	10	15
III	<p>Active Transducers</p> <p>Thermocouple - construction and principle - Measurement of angular velocity using Tachogenerator - Piezoelectric transducers - principle - measurement of pressure and vibrations - Hall effect Transducer - photo voltaic transducers (solar cell) - photo conductive transducer Measurement of radiation using Giger Muller tube.</p>	10	15
IV	<p>OPERATIONAL AMPLIFIERS</p> <p>Block diagram - DC, AC signal conditioning - operational amplifiers IC 741 – Pin details – Important terms – characteristics of ideal op amp - inverting and Non inverting mode –Gain - Applications of op. amps - Adders, Subtractor, Scale changer, integrator, Differentiator, Voltage to current converter - current to voltage converters - Differential amplifiers - Comparators (inverting and non inverting)</p>	11	15

Unit	Name of the Topic	Hours	Marks
V	<p align="center">SIGNAL CONDITIONERS IN INDUSTRIAL INSTRUMENTATION</p> <p>Operational amplifier with capacitive transducer - Operational amplifier as Instrumentation amplifiers – Bridge amplifier - active filters using op.amp - LPF, HPF – LPF as integrator - HPF as differentiator - Clipper, Clamper using op.amp. Successive Approximation ADC - R - 2R ladder network DAC - wein bridge oscillator using op.amp - op. amp as Zero crossing Detector.</p>	11	15

TEXT BOOK

Sl.No.	Title	Author	Publisher	Edition
	Transducers and Instrumentation	DVS Murty	PHI	2009

REFERENCE BOOKS

S. No	Title	Author(S)	Publishers	Edition
1.	Sensor and Transducers	D. Patranabis	PHI	2011
2.	A Course in Electrical and Electronics Measurements and Instrumentation.	1. A.K. Sawhney 2. Puneet Sawhney	Dhanpat Rai & Co (P) Ltd., New Delhi	1993
3.	Measurement and Instrumentation	Arun. K	PHI	2010
4.	Operational Amplifiers and Linear Integrated Circuits	Robert F. Coughlin Frederick F. Driscoll	PHI	1992
5.	Op. amp & Linear Integrated Circuits	Ramakant. A. Gayakwad	PHI	1992

MODEL QUESTION-1

Time – Three hours

Maximum Marks : 75

[N.B – 1. Answer any 15 questions from Part A Each Question carries 1 mark.

2. Answer all questions in part B choosing either (A) OR (B) in each Questions (OR) choosing either (A) (B) (OR) (C D) in each question. Each Question in part B carries 12 Marks.

PART – A

15 X 1 = 15

1. Define transducer
2. Mention the types of transducers.
3. Give an example for Active transducer.
4. Give two examples of Primary sensing elements
5. What is thermistor?
6. Expand LVDT and RVDT?
7. What is proximity sensor?
8. State any two applications of capacitive transducer
9. Distinguish between piezoelectric transducer and photo electric transducer.
10. Which device is used for the measurement of angular velocity?
11. Mention the principle of solar cell.
12. What do you mean by thermocouple?
13. Define signal conditioning.
14. List any two characteristics of ideal op. amp
15. What are the two types of comparators?
16. Define CMRR.
17. List different filters using op.amp.
18. Name the filter circuit that is used as an integrator.
19. What is clamper?
20. What do you mean by zero crossing detector.

PART – B

- 21 (A) 1. Briefly explain the classification of transducers. Give example in each. (6)
2. Write short notes on Bourden tubes and bellows. (6)
(or)
(B) 1. State the necessity and advantages of transducers . (6)
2. Discuss about Thermistors. (6)
- 22 (A) With neat sketches explain the operation of LVDT. List it's uses. (12)
(or)
(B) With neat sketches explain the operation of RVDT ; State it's applications. (12)
- 23 (A) Explain the construction and working of Piezo electric transducer with neat sketch. (12)
(or)
(B) Explain the construction and working of Geiger muller tube in radiation measurement. (12)
- 24 (A) 1. Explain the inverting mode operation of op. amp and derive equation for gain. (6)
2. Show how op. amp can be used as an adder. (6)
(or)
(B) 1. Draw and explain voltage to current converter using op. amp. (6)
2. Show how op. amp is used as differential amplifier . (6)
- 25 (A) With neat circuit explain the operation of Successive approximation A/D converter using op.amp. (12)
(or)
(B) With neat circuit and waveforms explain the operation of Zero crossing Detector using op. amp. (12)

MODEL QUESTION 2

Time – Three hours

Maximum Marks : 75

[N.B – 1. Answer any 15 questions from Part A Each Question carries 1 mark.

2. Answer all questions in part B choosing either (A) OR (B) in each Questions (OR) choosing either (A) (B) (OR) (C D) in each question. Each Question in part B carries 12 Marks.

PART – A

15 X 1 = 15

1. Give an example of passive transducer.
2. State any two advantages of transducer .
3. Define thermistor.
4. What are the types of thermistor.
5. What is proximity transducer?
6. State any two applications of strain gauge.
7. State the uses of LVDT.
8. Mention any one application of capacitive transducer.
9. State the principle of photo conductive transducer.
10. What is the basic principle of piezo electric transducer?
11. Name the devices used for measurement of Radiation
12. What do you understand by Hall effect?
13. Define slew rate.
14. Which IC is used as op. amp?
15. What is the value of bandwidth for ideal op.amp?
16. Write the formula to find output voltage of adder circuit using op.amp.
17. How many op. amps are used in Instrumentation amplifier?
18. What is clipper?
19. Which filter is used as differentiator?
20. What are the elements in Bridge amplifier?

PART – B

- 21 (A) With neat sketch, explain the construction and working of Metal Resistance Thermometer (12)
- (or)
- (B) With neat sketch, explain the operation of Digital encoding transducer. (12)
- 22 (A) What is an Inductive transducer? Discuss how it is used in the pressure measurement. (12)
- (or)
- (B) What is the principle of capacitive transducers? How it is used in liquid level measurement. (12)
- 23 (A) 1. Write short notes on thermocouple (6)
2. Draw and explain the measurement of angular velocity using tacho generator (6)
- (or)
- (B) 1. Write short notes on photo voltaic transducer. (6)
2. Draw and explain radiation measurement using Geiger muller tube. (6)
- 24 (A) 1. Explain the non inverting mode operation of op. amp. Derive equation for gain (6)
2. Show how op.amp can be used as an integrator. (6)
- (or)
- (B) 1. Explain any one comparator using op.amp with circuit and waveforms (6)
2. Show how op.amp can be used as a differentiator. (6)
- 25 (A) With neat circuit diagram explain instrumentation amplifier using op. amp (12)
- (or)
- (B) Draw the circuit of R. 2R ladder network DAC and explain its operation (12)

STATE BOARD OF TECHNICAL EDUCATION AND TRAINING, TAMIL NADU
SYLLABUS FOR DIPLOMA IN ELECTRICAL AND ELECTRONICS ENGINEERING
L-SCHEME

Course Name : Diploma in Electrical and Electronics Engineering
 Subject Code : **23045**
 Semester : IV Semester
 Subject Title : **Electrical Machines and Instrumentation Practical**

TEACHING AND SCHEME OF EXAMINATION

No. of weeks per Semester : 16

Subject	Instruction		Examination		
	Hours / Week	Hours / Semester	Assessment marks		
			Internal	Board Examination	Total
Electrical Machines and Instrumentation Practical	6	96	25	75	100

RATIONALE

Diploma programme is a Technician Education and therefore skill development is an important component in the Diploma programmes. To impart practical knowledge to the diploma students, practical subjects are introduced for every corresponding theory subject. This subject is very much helpful in understanding circuit connections and study the characteristics of electrical machines.

OBJECTIVES

On completion of this practical subject, the students will be able to

- Understand the characteristics of AC machines
- Various speed control methods of electrical motors
- Use various measuring instruments
- Make various electrical measurements
- Measure non-electrical measurements

**23045 Electrical Machines and Instrumentation Practical
DETAILED SYLLABUS**

Contents : Practical

List of Experiments

- (1) Predetermine the regulation of alternator by synchronous impedance method at (a) UPF
(b) 0.8 p.f lead (c) 0.8 p.f lag.
- (2) Load Test on Three Phase Alternator
- (3) Load Test on single phase Alternator.
- (4) Synchronizing of two alternators by Lamp method
- (5) Synchronizing of two alternators by Synchroscope
- (6) Conduct Load Test on a single phase induction motor and plot the performance curve.
- (7) Conduct Load Test on a single phase induction motor and plot the performance curve.
- (8) Conduct Load Test on a three phase slip-ring induction motor and plot the performance curve.
- (9) Find the equivalent circuit constants of a three phase induction motor by conducting No-Load and Blocked-Rotor tests
- (10) Draw the circle diagram for a three phase induction motor suitable by conducting tests and find the efficiency at different loads.
- (11) Demonstrate that power factor of an induction motor load is improved by connecting capacitor bank.
- (12) Calibration of given Ammeter and Voltmeter and plot the error graph
- (13) Calibration of given Wattmeter and plot the error graph
- (14) Calibration of single phase energy meter using RSS meter
- (15) Calibration of Three phase energy meter using Wattmeter and Stop Clock

- (16) Find the winding resistance of alternator winding resistance using Wheatstone bridge.
- (17) Find the value of unknown capacitor using Schering's bridge.
- (18) Find the value of unknown inductance BY Anderson Bridge.
- (19) Displacement measurement using LVDT.
- (20) Measurement of earth-resistance by using earth-test kit.

Scheme of Evaluation

SI No.	Activity of the Candidate	Maximum Marks to be awarded
1	Drawing Correct Diagram and writing Details of the Components/Equipments/Machines used	15
2	Making the correct circuit connections	15
3	Conducting the Experiment <ul style="list-style-type: none"> - Following the correct procedure - Taking the appropriate readings - Following the appropriate safety procedure 	25
4	Tabulation of Readings Interpretation of Results Graphical Representation (if required)	15
5	Viva-voce (Questions related to the given experiments only)	5
	Total Marks (External)	75

ELECTRICAL MACHINES AND INSTRUMENTATION PRACTICAL

Sl. No.	LIST OF EQUIPMENTS	Quantity Required
1	Synchronous Motor 1 HP	1
2	3 Phase Squirrel cage Induction motor 5 HP 440V/20A	1
3	1 phase Induction motor 1 HP 230V/0.5A	1
4	3 phase Slip ring Induction motor 5HP 440V/20A	1
5	AC Ammeter (0-2)A	2
6	AC Ammeter (0-15)A	2
7	AC Ammeter (0-10)A	2
8	AC Ammeter (0-5)A	5
9	DC Ammeter(0-2)A	3
10	AC Voltmeter (0-300)V	3
11	AC Voltmeter(0-600)V	6
12	Wattmeter (0-24)V,5A,10A	3
13	Wattmeter (0-60)V,5A,10A	7
14	Wattmeter (0-750)W wattmeter multi range 1500W-10A,3000W-	1
15	Wheatstone bridge	2
16	Anderson Bridge	2
17	Schering Bridge	2
18	1 Phase Energy meter Calibration Induction Type	1
19	3 Phase Energy meter Calibration Induction Type	1
20	Earth Resistance Kit	2
21	LVDT Kit to measure Displacement	2
22	Load Cell calibration various Load arrangement	2
23	Alternator 1 phase	1
24	Alternator 3 phase	1
25	Tachometer Analog type	2
26	Tachometer Digital	1
27	Synchroscope	1
28	Frequency meter	2
29	PF meter (paver factor meter)	2
30	Single phase R.S.S meter	1
31	3 phase R.S.S meter	1

STATE BOARD OF TECHNICAL EDUCATION AND TRAINING, TAMIL NADU
SYLLABUS FOR DIPLOMA IN ELECTRICAL AND ELECTRONICS ENGINEERING
L-SCHEME

Course Name : Diploma in Electrical and Electronics Engineering
Subject Code : **24046**
Semester : IV Semester
Subject Title : **DIGITAL ELECTRONICS AND LINEAR ICS PRACTICAL**

TEACHING AND SCHEME OF EXAMINATION

No. of weeks per Semester : 16

Subject	Instruction		Examination		
	Hours / Week	Hours / Semester	Assessment marks		
			Internal	Board Examination	Total
DIGITAL ELECTRONICS AND LINEAR ICS PRACTICAL	5	80	25	75	100

RATIONALE

Diploma programme is a Technician Education and therefore skill development is an important component in the Diploma programmes. To impart practical knowledge to the diploma students, practical subjects are introduced for every corresponding theory subject. This subject is very much helpful in understanding working of some important Linear and Digital Integrated Circuits.

OBJECTIVES

On completion of this practical subject, the students will be able to

- Understand the functioning of Logic Gates
- Make use of various Digital ICs
- Understand the functioning of Counter circuits
- Understand the functioning of Analog to Digital and Digital to Analog Converters

24046 DIGITAL ELECTRONICS AND LINEAR ICS PRACTICAL DETAILED SYLLABUS

Contents : Pracical

1. Verification of truth table of OR, AND, NOT, NOR, NAND, EX-OR gates.
2. Realization of basic gates using NAND & NOR gates.
3. Realization of logic circuit for a given Boolean expression..
4. Half adder, Full adder using discrete IC's.
5. Half subtractor, full subtractor using discrete IC's.
6. Construction and verification of truth table for Decoder/Encoder.
7. Multiplexer/De-multiplexer using discrete IC's.
8. Parity generator and checker using discrete IC's.
9. Construction and verification of truth table for RS, D, T, JK, flip-flop.
10. 4- bit ripple counter using FF
11. Single digit counter using 7490, 7475, 7447 & seven segment LED.
12. Construct and test digital data generator using shift registers.
13. Inverting Amplifier and Non inverting Amplifier with AC signal using OPAMP.
14. Integrator and Differentiator using Opamp
15. Summing amplifier & Differential amplifier using Opamp.
16. Astable and Monostable multivibrator using IC 555.
17. IC voltage regulator using IC 78XX, IC 79XX and LM317 for
1.2 v to 12v.
18. DAC using R-2R network, Binary weighted resistor network.

Scheme of Evaluation

SI No.	Activity of the Candidate	Maximum Marks to be awarded
1	Drawing Correct Diagram and writing Details of the Components/Equipments/Machines used	15
2	Making the correct circuit connections	15
3	Conducting the Experiment <ul style="list-style-type: none">- Following the correct procedure- Taking the appropriate readings- Following the appropriate safety procedure	25
4	Tabulation of Readings Interpretation of Results Graphical Representation (if required)	15
5	Viva-voce (Questions related to the given experiments only)	5
	Total Marks (External)	75



DIPLOMA IN ENGINEERING/TECHNOLOGY

**L - SCHEME
2011 - 2012**

COMMUNICATION AND LIFE SKILLS PRACTICAL

**DIRECTORATE OF TECHNICAL EDUCATION
GOVERNMENT OF TAMILNADU**

L-SCHEME
(Implemented from the Academic year 2011-2012 onwards)

Course Name : DIPLOMA IN ENGINEERING/TECHNOLOGY

Subject Code : **20002**

Semester : **IV or V SEMESTER**

Subject Title : **COMMUNICATION AND LIFE SKILLS PRACTICAL**

TEACHING AND SCHEME OF EXAMINATION:

No. of Weeks per Semester: 16 Weeks

Subject Title	Instructions		Examination			
	Hours/ Week	Hours/ Semester	Marks			Duration
			Internal assessment	Board Examination	Total	
COMMUNICATION AND LIFE SKILLS PRACTICAL	4 Hours	64 Hours	25	75	100	3 Hours

Topics and Allocation of Hours:

Sl. No.	Section	No. of Hours
1	Part-A: Monodic Communication	16
2	Part-B: Dyadic Communication	16
3	Part-C: Professional Communication	16
4	Part-D: Life Skills	16
Total		64

RATIONALE

Nowadays, effective and errorfree communication is a basic need. Communication through English is the order of the day for entry and survival in any corporate. Training in Monodic communication (one man communication) Dyadic communication (a pair communication) and Professional communication (may be Monodic, Dyadic or Group communication) is attempted through these practical modules. One can improve one's communication skills by enriching one's vocabulary ,particularly active vocabulary and standard everyday expressions and using them in various contexts. Practice alone, both on the campus and outside the campus, can help a learner to grow proficient in the art of Communication.

Language is the most commonly used and effective medium of self-expression in all spheres of human life - personal, social and professional. A student must have a fair knowledge of English language use and various communicative functions. He/she must be able to pursue the present course of study and handle the future jobs in industry. The objective of the course is to assist the diploma holders to acquire proficiency in monodic, dyadic and professional communication skills and selective but most important life skills. At the end of the course, the student will be able to communicate his ideas fearfree and errorfree, in social and professional spheres of life and imbibe life skills.

SPECIFIC INSTRUCTIONAL OBJECTIVES

Communication is crucial as it influences every aspect of one's personal development. Having a sound grounding in reading and writing techniques allows a student to progress on to higher level literacy skills. Many students struggle because their basic decoding is so inaccurate that advanced comprehension is difficult for them. Because of their poor exposure and poor use of English language in various spheres of life they suffer proper communication. They also tend to be 'afraid' of words and in turn they are not able to develop their personal vocabulary. In otherwords, without solid literacy skills, the student's prospects and life chances are limited. It is a fact that Communication skills and Life Skills shapes one's personality.

MONODIC COMMUNICATION

The student is able to:

1. Practise using departmental words and terminology in sentences.
2. Prepare and perform oral presentations.
3. Introduce oneself and others.
4. Deliver welcome address and vote of thanks.
5. Compere a program.
6. Describe the visuals.
7. Take notes, answer very short questions.
8. Comprehend an auditory/oral passage.

DYADIC COMMUNICATION

The student is able to:

1. Adopt various communicative functions.
2. Prepare and perform a dialogue.
3. Adopt the basics of telephone etiquette.

PROFESSIONAL COMMUNICAITON

The student is able to:

1. Prepare a resume.
2. Take part in a group discussion.
3. Communicate through body language.
4. Adopt the interview skills with professional presence.
5. Perform mock interview.

LIFE SKILLS

The student is able to:

1. Prepare for and deal with change.
2. Adopt motivation, goal setting and self-esteem.
3. Adopt Teamwork skills.
4. Adopt Time management.
5. Adopt Emotional intelligence skills.
6. Assert Positively.
7. Adopt Interview etiquette.
8. Plan career.
9. Understand Strength, weakness (long term, short term).

LEARNING STRUCTURE

To enable the students to practise monodic communication, dyadic communication professional communication and imbibe life skills through various modes of practical learning and assignments.

PROCEDURE	MONODIC COMMUNICATION	DYADIC COMMUNICATION	PROFESSIONAL COMMUNICATION	LIFE SKILLS
PRINCIPLES	Identifying various platforms	Exposure to dialogue situations, exposure to telephone etiquette.	Exposure to resume writing, group discussion, interviews.	Exposure to selective life skills/problem solving skills.
CONCEPTS	Sharing opinions, feeling, with or without audience.	Understanding the basic communicative functions. Conversing with a neighbour	Writing resume, performing group discussion, facing interviews.	Imbibe and practise the selective life skills.
FACTS	Oral presentation, art of introduction, enhancing the list of active vocabulary, listening skills, note taking skills, describing skills.	Audio tapes, compact disk, mikes, various contexts.	FAQ, Resume models, Audio tapes, compact disk, mikes.	Stories, anecdotes, incidences, case studies and assignments.

COMMUNICATION AND LIFE SKILLS PRACTICAL

SYLLABUS

PART A: MONODIC COMMUNICATION

(16 hours/ periods)

- a) **Vocabulary enrichment:** recording important words and terminology alphabetically connected to the concerned department – playing antakshari.
- b) **Introducing oneself:** using greeting phrases – opening and closing with courteous notes – supplying personal information.
- c) **Introducing others:** using greeting phrases – opening and closing with courteous notes – with information.
- d) **Welcome address, vote of thanks and compering a program:** keeping notes – and personal information of the dignitaries – concerned.
- e) **Making an Oral Presentation:** Preparing the presentation - Talking about people, animals and places – Keywords technique and the rehearsal – Presentation outline – Performing the presentation – answering the questions.
- f) **Oral description:** a picture from an English magazine – a visual ad – a natural scene.
- g) **Auditory/Oral comprehension** – small passage – small dialogue -very short story – note - taking skill.
- h) **News Caption:** giving caption for a news item from an English daily.

PART B: DYADIC COMMUNICATION: COMMUNICATIVE FUNCTIONS (16 hours/ periods)

- a) **Dialogue:** preparing and performing - Meeting people, exchanging greetings and taking leave – Giving instructions and seeking clarifications – Thanking someone and responding to thanks - minimum seven exchanges including the courteous openings and closings – ten common contexts.
- b) **Telephonic dialogue:** telephonic etiquette - Answering the telephone and asking for someone – Dealing with a wrong number – Taking and leaving messages – Making enquiries on the phone-ordering for supply-bookings and arrangements-handling the complaints – calling for appointment.

PART C: PROFESSIONAL COMMUNICATION

(16 hours/ periods)

- a) Group Discussion - Taking part in a Group Discussion – focus on team spirit.
- b) Interview - Frequently asked questions in an interview – Mock interview - Body language.
- c) Resume Writing – components.

PART D: LIFE SKILLS

(16 hours/ periods)

- a) Preparing for and dealing with change.
- b) Motivation, goal-setting and self-esteem.
- c) Teamwork skills.
- d) Time management
- e) Emotional intelligence skills
- f) Career planning.
- g) Assertive Skills.
- h) Interview skills.

References :-

- 1) Malcolm Goodale, Professional Presentations with VCD, Cambridge University Press
- 2) B.Jean Naterop and Rod Revell, Telephoning in English with 2 Audio CDs Cambridge University Press
- 3) Priyadarshi Patnaik, Group Discussion and Interview Skills with VCD, Cambridge University Press
- 4) Kamalesh Sadanand and Susheela Punitha, Spoken English: A Foundation Course for Speakers of Tamil, Orient BlackSwan.
- 5) S. P. Dhanavel, English and Soft Skills, Orient BlackSwan
- 6) Robert Sherfield and et al, Developing Soft Skills, Pearson Education.
- 7) Poly Skills: A course in communication skills and Life skills, Cambridge University Press
- 8) English and Communication Skills for Students of science and Engineering by S.P.Dhanavel , Orient BlackSwan.
- 9) Speak Well, edited by Kandula Nirupa Rani, Jayashree and Indira, OrientBlackSwan.
- 10) Fifty ways to improve your telephoning and teleconferencing Skills by Ken Taylor -

COMMUNICATION AND LIFE SKILLS PRACTICAL

Model Question Paper – 1

Time: 3 hrs

Max Marks: 75

PART –A (35 Marks)

Monodic Communication:

1. Introduce one self (5)
2. Use the mentioned words orally in sentence (2x2 ½ =5)
3. Prepare and present a welcome address for your college annual day programme. (5)
4. Listen to the passage read out from the English daily of the week of the examination. Please note: No prerecorded passage (10)
5. Write a news caption for the passage given from the English daily. (5)
6. a) Describe orally the visual or the picture found in the English daily of the week of the examination. (5)

(Or)

- b) Make an oral presentation about an animal.

PART – B (15 Marks)

Dyadic Communication:

1. Play antakshari of five pairs of departmental words with your partner. (5)
2. Prepare and perform a dialogue with your partner on the given situation (10)

(minimum seven exchanges)

Or

Prepare and perform a telephonic dialogue on a flight booking.

(minimum seven exchanges)

PART-C (25 Marks)

Professional Communication:

1. Form a group of six members and perform a discussion on the given theme. (10)
2. Imagine you are V.Gokulraj ,a diploma holder. Prepare a resume for the post of supervisor in Oberoi computers Ltd.Chennai. (10)

Professional appearance: Interview etiquette-dress code- Body language (5)

**COMMUNICATION AND LIFE SKILLS PRACTICAL
Model Question Paper - 2**

Time: 3 hrs

Max Marks: 75

PART –A (35 Marks)

Monodic Communication:

1. Introduce your friend S.Mohan an a excutive engineer to a group of audience. (5)
2. Use the mentioned words in sentence orally. (2x2½ =5)
3. Prepare and present a Vote of thanks in your college sports day programme. (5)
4. Listen to the passage read out from the English daily of the week of the examination. Please note: No prerecorded passage (10)
5. Write a news caption for the passage given from the English daily. (5)
6. a) Describe the visual or the picture found in the English daily of the week of the conduct of the examination. (5)

(Or)

- b) Make an oral presentation about your polytechnic college.

PART – B (15 Marks)

Dyadic Communication:

1. Play antakshari of five pairs of your departmental words with your partner. (5)
 2. Prepare and perform a dialogue with your partner on the given situation (10)
- (minimum seven exchanges)

(Or)

- Prepare and perform a telephonic dialogue on ordering the supply of a computer
(minimum seven exchanges)

PART-C (25 Marks)

Professional Communication:

1. Form a group of six members and perform a discussion on the given theme. (10)
2. Imagine you are M.Kishore a diploma holder. Prepare a resume for the post of operating engineer in REC Electricals Ltd.Madurai. (10)
3. **Professional appearance:** Interview etiquette-dress code- Body language (5)

NOTES OF GUIDANCE

Role of the media:

To equip a learner with vocabulary, particularly active vocabulary and standard everyday expressions, using English dailies and watching selective English T.V. channels both in the classroom and outside the classroom is focused. Such a provision is recommended for the students to establish familiarity with the English dailies and selective English T.V. channels.

Minimum two copies of two English dailies in the laboratory room (students can bring their own copies also). Minimum two systems with net connection for information collection in the laboratory itself.

Synopsis of the news item:

During every lab work day, students must choose a news item from the English daily or weekly or monthly, and write a synopsis of the chosen news item, in not more than five lines. The news item should be pasted on the left page and synopsis on the right page (the chosen news item should not be politically, socially or communally controversial). Students should exercise care in choosing the news items. Teachers have to advise them on this aspect. This can be done outside the class hours also but every record exercise should begin with the synopsis of news item of the date of the lab session.

For example, first lab exercise namely departmental vocabulary and antakshari is performed on 15/12/2011. The student should choose a news item from any English daily of 15/10/2011 and record the synopsis on the right page (in not more than 5 lines) under the caption **Synopsis of the news item of the day/date 15/10/2011**. There is no harm in repeating or copying the lines from the passage. The essence of the passage should be there. The cutout news item for presenting the synopsis should be pasted on the left page of the record notebook.

This is to be done with interest for developing one's personality. This work **does not carry any marks** but without which the record exercise should not be valued. This is the precondition for valuing the record exercise. Each record exercise follows the synopsis of the chosen news item.

At the bottom of the synopsis, the student should record the **dictionary meaning** of at least **one strange word** found in the chosen news item. At the end of every month, a minimum of 10 Headlines of 10 different days i.e. one Headline a day from anyone English daily should be pasted on the right or left page of the Record Note Book. (This work does not carry marks but this is the precondition for marking the record exercises)

External examiner, before signing the record notebook, should verify whether the Newspaper works were recorded/pasted in the record notebook.

Verbal communication in any language begins with sounds in isolation, union and word formation. Learning everyday words and expressions is the primary factor. Grammar comes next. One can enrich one's every day vocabulary by reading English magazines and listening to or watching an English channel on television. So an English laboratory should be equipped with a minimum of two copies of two English dailies and English weeklies or monthlies.

Watching English channels helps the students improve their vocabulary and expressions. If there is a provision, students may be permitted to watch selective, mind corruption free English channels (sports, education, news, animal channels and so on) for at least 15 min. during the English lab sessions. This will serve as motivation for the students and help them shed their inhibition.

What is antakshari? (Polar word game)

This game can be played on the stage by two or three students using the departmental words. Suppose Mr. A belongs to Dept.of Electrical and Electronics and he says his departmental word '**ampere**'. Mr. B has to supply a word beginning with the ending letter of Mr. A's word. The word **ampere** ends with the letter '**e**' so Mr. B says '**electrical**'. Mr. A has to continue with the letter '**l**'. Like that five pairs of words are to be spoken. (**Letter ending only, not sound ending.**) Suppose departmental words are not available in some English letters like 'x', 'y', 'z' the students may be permitted to use common words.

ANTAKASHARI (Five Exchanges)
(Dept. of Mechanical Engineering.)

EXAMPLE:

- Mr. A
1. Governor
 2. Rack
 3. Nut
 4. Lathe
 5. Naphtha

- Mr. B
- Reservoir
 - Kelvin
 - Tool
 - Emission
 - Anvil

Introducing oneself:

One is not expected to introduce one's family. One or two sentences on his family will do. Care must be taken to include general proficiency, titles and merits, awards possessing or secured in academic activities like paper presentation, participation in inter polytechnic or intra polytechnic competitions, sports activity, forums like NCC, NSS, hobby, ambition, strengths and weaknesses.

Introducing others – merits – credentials—one or two points on his family.

Vote of thanks / Welcome address. No doubt it should be all-covering but Focus should be on the important persons/invitees/chief guest and the message of the speaker.

Description (pictures from English weekly/daily) Pictures may be displayed through projector or Magazine cuttings may be used. Just five lines on the picture will do.

Auditory/oral comprehension: A Passage from any English daily of the week of the examination is to be read out for two to three minutes in the end examination. Display of recorded passages can be used as an addition in the class room. The use of pre-recorded passage discouraged in the end examination.

Oral presentation: Students must be encouraged to use English magazines and internet for collecting information on the topic, noting keywords and use them in their presentation in his own language. One must be able to talk extempore for 2 min on any topic, given a time of two minutes for organizing his/her thoughts. The topics can be kept simple and general (current events of interest like sporting event for headline of the day). It must be totally an oral activity without the aid of any other media.

News Caption: A news item ,without heading,of not more than ten lines from an English daily of the week of the conduct of Examination is to be given. The caption may be a passive construction or a catchy phrase on the given news item.

Face to face dialogue: Selective nine situations / topics are to be performed in the class room. (Minimum seven exchanges with courteous openings and closings).

Telephonic dialogue: Selective seven situations to be given. (Minimum seven exchanges).

Resume writing: cover letter—the components of a resume like sender's address, recipient's address, career objective to be explained.

Group Discussion: Topics of common interest, avoiding controversial ones, are to be given for discussion. A group may consist of six members.

Students should be exposed to 44 phonemes (sounds) in English language and their symbols.

There shall be no question on this end examination.

COMMUNICATION SKILLS EXERCISES:-

1. Departmental Vocabulary alphabetically (using it in sentence, antakshari). Using the words orally in sentences
2. Introducing oneself and others
3. Vote of thanks / Welcome address
4. Description (pictures from English weekly/daily)
5. Auditory/oral comprehension
6. Oral presentation
7. Face to face dialogue
8. Telephonic dialogue
9. Resume writing
10. Group Discussion

Communication Skills:

Ten Marks for each exercise leading to a maximum of hundred marks in total.
The total marks to be reduced to an average of ten marks.

Texts of the performed activities to be recorded in the Record Note book. Synopsis of the news item of the day/date is mandatory at the beginning of every record exercise.

Life Skills:

- i) Preparing for and dealing with change.
- j) Motivation, goal-setting and self-esteem.
- k) Teamwork skills.
- l) Time management
- m) Emotional intelligence skills
- n) Career planning.
- o) Assertive Skills.
- p) Interview skills.

Life skills are to be intensely inculcated through lectures, quotes, anecdotes and case studies. An excellent awareness of the eight essential life skills is to be created through continuous internal assessment. Five assignments in these topics are to be recorded in the record note book.

- A minimum of five assignments on five different topics.
- Each assignment to be assessed for twenty marks.
- The total marks to be reduced to an average of ten marks.
- All the topics to be covered in the lab.

TIME MANAGEMENT IN THE END EXAM.

For written part 30 min

- Written part of the examination should be the first / beginning of the examination, monadic oral exam to start during the written exam.

Written Part exercises:

- auditory / oral comprehension.
- Resume writing.
- Giving news caption for the passage.
- During the written examination time of 30 minutes, monadic communication examination may also take place simultaneously.

MONODIC COMMUNICATION (ONE MAN COMMUNICATION)

Oral part – 75 min.

Both internal and external examiners (simultaneously) are to examine the students.

Five minutes for each student. 15 students for external & 15 students for internal and within 75 minutes both internal and external examiners complete the monadic communication exam.

DYADIC COMMUNICATION (ONE PAIR COMMUNICATION)

- 5 min for each pair.
- 15 pairs in total. 8 pairs for external and 7 pairs for internal examiner. (8x5=40 min) within **40 min** both internal and external examiners completes the dyadic communication exam.
- The students examined by the external for monadic exam are to be examined by the internal for dyadic and vice versa.

PROFESSIONAL COMMUNICATION

- 30 min for group discussion.
- 6 members in each group.
- 5 min for discussion for each group.
- Both internal and external examiners to supervise / examine simultaneously one group each.
- Within fifteen minutes all the six groups to be examined.

LABORATORY REQUIREMENT

1. An echo-free room for housing a minimum of sixty students.
2. Necessary furniture and comfortable chairs
3. Public Address System.
4. A minimum of two Computers with internet access, with Audio for Listening Skill and related software packages.
5. A minimum of Two different English dailies.
6. A minimum of one standard Tamil daily.
7. Headphone units – 30 Nos. with one control unit with a facility to play and record in Computer.
8. A minimum of Three Mikes with and without cords.
9. Colour Television (minimum size – 29”).
10. DVD/VCD Player with Home Theatre speakers.
11. Clip Chart, white board ,smart board.
12. Projector.
13. video camera.
14. Printer,Xerox,scanner machines **desirable**.
15. English Weeklies/monthlies/journals like ELTOI **desirable**.
16. Frozen thoughts –monthly journal for Lifeskills by Mr.Rangarajan / www.frozenthoughts.com

Mark Pattern

End Examination – 75 Marks

Monodic Communication – 35 Marks

Dyadic Communication – 15 Marks

Profession Communication – 20 Marks

Professional Appearance – 5 Marks

Internal Assessment

25 Marks

Communication skills Record Notebook 10 Marks

Life skills assignments 10 Marks

Attendance 5 Marks

COMMUNICATION AND LIFE SKILLS PRACTICAL

Allocation & Statement of Marks

Duration:3Hrs.

Name of the Candidate

Reg. No.

A. Monodic communication : 35 Marks

Introduction (5 mks)	Use in sentence (5 mks)	Vote of thanks / welcome address (5 mks)	Auditory/Oral comprehension (10 mks)	Description/ Oral presentation (5 mks)	News caption (5 mks)	Total (35 mks)

B. Dyadic communication: 15 Marks

Antakshari (5 mks)	Dialogue (10 mks)	Total (15 mks)

C. Professional communication: 20 Marks

Group Discussion (10 mks)	Resume (10 mks)	Total (20 mks)

D. Internal Assessment: 25 Marks

Record Notebook Commn.skills (10 mks)	Assignments Life Skills (10 mks)	Attendance (5 mks)	Total (25 mks)

E. Professional Appearance:

/5 Marks

Total :

/100 Marks

Internal examiner

External examiner

FACE TO FACE DIALOGUE TOPICS

1. Between Friends (On any acceptable topic).
2. Between a conductor and a passenger.
3. Between a doctor and a patient.
4. Between a Shopkeeper and a Buyer.
5. Between a Teacher and a Student.
6. Between a tourist and a guide.
7. In a Bank.
8. At a railway enquiry counter.
9. Lodging a complaint.

Note: A resourceful teacher may add a few more topics of common interest.

TELEPHONIC DIALOGUE TOPICS

1. Placing an order.
2. Making Enquiries.
3. Fixing appointments
4. Making a hotel reservation.
5. Dealing with a wrong number.
6. Travel arrangements.
7. Handling complaints.

MECHANICAL DEPARTMENTAL VOCABULARY FOR ANTAKASHARI AND USING IN SENTENCES

EXAMPLE:

A:

1. Anvil – made of cast Iron used in foundry shop.
2. Axle – A metal rod that connects two wheels.
3. Alloy – alloy is a mixture of two or more metals.
4. Addendum – distance between top of gear teeth and pitch circle.
5. Annealing – It is a heat treatment process for softening the metals.

B:

1. Bearing – it is which supports the shaft.
2. Bolt – it is a type of fastener. Combined with screw.
3. Brake – it is used to halt an auto mobile vehicle.
4. Beed – steel wiring used in tyres to withstand stress.
5. Baffles – it is used to reduce noise, filter dust particles in auto mobile.

C:

1. Cam – it is a lobe like structure, which actuates the valve.
2. Crown – the slope like structure in the piston.
3. Calipers' – they are measuring instruments.
4. Clutch – it is used to disengage and engage the fly wheel and main shaft.
5. Chamber – it is the distance between vertical line and tyre center line.

D:

1. Damper – it is a type of shock absorber, reduces the vibration.
2. Differential – it controls the speed of rotating wheel in the rear axis.
3. Diaphragm – it is used to separate two layers.
4. Detonation – it is the continuous knocking with serious effect on cylinder head.

E:

1. Evaporator – it absorbs heat to vapourise liquid into air
2. Engine-the place where fuel is burnt and heat energy is converted. mechanical energy
3. Electrolyte-it is a liquid substance which is used to transfer current or any metal particle.
4. Emission-the release of burnt gas from automobile.
5. Elongation-the increase of dimension due to application of load.

F:

1. Filter-which is used to remove dust particles.
2. Friction-the resistance on wear occur due to rubbing of two metals.
3. Fly wheel-the wheel like structure used to balance the uneven weight in engine.
4. Fuel – it is a substance that burns with oxygen in the air.
5. Factor of safety - it is the safety limit after which the material will break down.

G:

1. Governor – it is used to control the flow of fuel according to load.

2. Gear – it is used to transmit power from one place to another.
3. Generator – it is used to generate power.
4. Gasket – it prevents the leakage and to provide sealing effect.
5. Goggle – the protective device used to guard the eyes.

H:

1. Hub – it is the center part of wheel.
2. Hammer – it is used to beat sheet metals.
3. Hydraulics – it deals with fluid for various function.
4. Hatching – it is used to highlight the parts in drawings.
5. Head stock – it is the main function unit of lathe.

I:

1. Ignition – it is the function by which fuel is burnt.
2. Injection – it is the process of spraying fuel into engine block.
3. Impeller – it is which converts kinetic energy into pressure energy.
4. Inventory – it is the place where raw materials are stored.
5. Idling – it is the condition at which the automobile engine at stationary state.

J:

1. Jig – it guides the tool and hold the job.
2. Jaw – it is teeth like structure used to hold work pieces.
3. Jog mode – Jog mode is used to give manual feed for each axis continuously.
4. Junk – it is known as waste material in industry.
5. Journal – It is a type of bearing.

K:

1. Keyway – it is a specific path made in shaft to joint parts.
2. Knocking – the sound produced due to Burning of uncompleted burnt fuel.
3. Kelvin – it is the degree of hotness.
4. Knurling – it is the process of lathe done to work piece to improve the gripness.
5. Knuckle joint – It is a type of joint used to connect two work pieces.

L:

1. Lubrication – process of reducing heat by applying cooling substances.
2. Layering – it is used to draw parts of a machine separately and combine together.
3. Lever – it is a supported arm used to engage gears.
4. Lathe – it is the father of machines used in turning operations.
5. Lead screw - it is the screw through which the carriage travels.

M:

1. Manometer – it is used to measure the pressure of fluids.
2. Milling – process of removing metal from work piece by rotating cutting tool.
3. Manifold – it is a passage made for flow of fuel in automobile.
4. Moulding – it is the process of passing hot liquid metal into mould made through sand.
5. Module – it is a metric standard used to identify or specify pitch.

N:

1. Nozzle – it is used to reduce the pressure and increases the velocity.
2. Nut – it is a type of fastener used to couple with screw.
3. Nomenclature – Dimensional property of specific part on component is notified by nomenclature.
4. Neck – Distance between drills body and shank.
5. Naphtha – kind of inflammable oil.

O:

1. Orthography – it is the three dimensional view of an object.
2. Ovality – Elliptical shape of piston.
3. Over haul – it is the complete checking and servicing of a machine or vehicle.
4. Optimum temperature – suitable temperature condition for certain process on working.
5. Offset – it is by which the axis of certain job is defined.

P:

1. Pinion – a small gear is called pinion.
2. Pulley – A cylindrical object used to connect belt for transmitting power.
3. Pump – it is which transfers fluid from one place to another.
4. Piston – it is which transfer power from combustion chamber to connecting rod.
5. Port – it is the opening in two stroke engine for movement of fuel and exhaust.

Q:

1. Quilt – it is used to give automatic feed in machines.
2. Quality control – it is an inspection process!

R:

1. Reaming – it is the operation used to finish inner surface of a hole.
2. Reservoir – it is used to store fuel or any liquid.
3. Rack – it is a spur gear with infinite radius.
4. Retainer – it is used to bring back to the original position.
5. Radiator – it is the part used in automobile for cooling water.

S:

1. Shackle – it is a rod connected to leaf spring.
2. Spring – it is a circular rod which compresses on load and retracts when released.
3. Strainer – it is used to remove micro particles.
4. Shock absorber - it is used to reduce vibration and give cushioning effect.
5. Suspension- it is used to absorb shocks and give cushioning effect.

T:

1. Tail stock – it is used in lathe to support the job.
2. Tool – it is a metal removal device.
3. Torque – it is the twisting load given on a work piece.
4. Trimming – it is the process of removing excess metal .
5. Turning – it is a metal cutting process used to reduce diameter.

U:

1. Universal joint-it is used to connect propeller shaft and differential unit.
2. Universal divider head- it is used to index various components.

V:

1. Valve – valve is the part used in automobile for flow of fuel and exhaust to cylinder head.
2. Vent hole – it is the hole made in casting for ventilation purpose.
3. Vulcanizing – it is the process of adding carbon to rubber.
4. Vibration – it is caused due to the movement in an uneven surface.
5. Velocity-rate of change of displacement.

W:

1. Wheel-it is a circular object which rotates and moves the vehicle.
2. Wiper-it is used in wind shield to remove water droplets.
3. Work piece-it is the material in which various processes are done to make a component.
4. Wage-it is the amount paid to a worker for his work.
5. Washer-washer is a component used in fasteners to reduce gap.

Y:

1. Yawing-the turning of wind mill towards direction of air is called yawing.
2. Yoke-it is which holds the other end of spindle in milling machine.
3. Yield stress-It is the stress above which it will attain the breaking stress.
4. Young's modulus-it is the ratio between stress and strain.

Pl.note: Suppose departmental words are not available in some English letters like 'x', 'y', 'z' the students may be permitted to use common words. This is only an example. Another student of Mechanical Engineering can have different sets of words under each letter of the English alphabet. Like that there may be variety of sets. The most important point is that One is not supposed to murmur but speak the words intelligibly in an audible manner. Swallowing the words will deprive a student of winning a selection in an interview. In the same way, students of other Departments can have different sets of words of their departments under each letter of the English alphabet.

TELEPHONE LANGUAGE AND PHRASES IN ENGLISH

Answering the phone

" Good morning/afternoon/evening, Madras Enterprises, Premila speaking."

" Who's calling, please?"

Introducing yourself

" This is Raghavan speaking."

" Hello, this is Raghavan from Speak International."

Asking for someone

" Could I speak to Mr. Raman, please?"

" I'd like to speak to Mr Raman, please."

" Could you put me through to Mr Raman, please?"

" Could I speak to someone who ..."

Explaining

" I'm afraid Mr. Raman isn't in at the moment".

" I'm sorry, he's in a meeting at the moment."

" I'm afraid he's on another line at the moment."

" Putting someone on hold"

" Just a moment, please."

" Could you hold the line, please?"

" Hold the line, please."

Problems

" I'm sorry, I don't understand. Could you repeat that, please?"

" I'm sorry, I can't hear you very well. Could you speak up a little, please?"

" I'm afraid you've got the wrong number."

" I've tried to get through several times but it's always engaged."

" Could you spell that, please?"

Putting someone through

" One moment, please. I'll see if Mr Raman is available."

" I'll put you through."

" I'll connect you."

" I'm connecting you now".

Taking a message

" Can I take a message?"

" Would you like to leave a message?"

" Can I give him/her a message?"

" I'll tell Mr. Raman that you called"

" I'll ask him/her to call you as soon as possible."

" Could you please leave your number? I shall ask him to get back to you."

Pl.note: The above ones are samples only. A resourceful teacher may add more.

DAY-TO-DAY EXPRESSIONS (For dialogues)

COMMON PARLANCE

How are you?
Fine. Thank you.
How are you?
Me too.
How do you do?
How do you do?
It's good to see you again.
Glad to meet you.
Thank you.
Thanks very much.
Welcome.

Hello! How is everything?
Just fine. Thanks. What's new?
Nothing much.

I'm pleased to meet you.
The pleasure is mine.
I've heard Paul speak about you often.
Only good things! I hope.

Look who's here!
Are you surprised to see me?
Sure. I thought you were in Chennai.
I was, but I got back yesterday.

Sorry, May I help you?
So kind of you.
That's so nice of you.
Nice talking to you.
Nice meeting you.
It's getting late, and I've to go now.
Certainly. Come back soon.
In that case, I'll be seeing you.
Fine.
Thank you.
Welcome
So long. See you later.
Take care. Bye.
Good-bye.

Could you tell me the time, please?
Certainly. It is 5.35 p.m.
My watch says 5.40 p.m.
Then your watch is five minutes fast.

Excuse me. Can you tell me the way to ...?
May I come in?
How is the weather today?
It is pleasant. / sunny / rainy / warm /windy.

I am sorry, Can you repeat what you have said.

I am sorry, I can't hear you properly.
It is not audible. Can you please repeat it?
Beg your pardon; I don't get your words clearly.
How do you feel now?
Are you ok?
I am fine. And how about you?
I am fine. Thank you.

GROUP DISCUSSION

Let me begin with introducing this concept,
Well, this is to convey that
At the outset, I am here to convey
At this juncture, I would like to
May I intervene?
May I add?
Kindly permit me to say
If you could allow me to say
Let me add a few words
Let me first answer your question
Can you please allow me to convey
Excuse me; I would like to add further

On behalf of my colleagues,
On their behalf
Firstly/ secondly/ thirdly.
Finally/ conclusively/ at the end / Summing up
Eventually/ in the event of
In spite of / otherwise/ although/ though

Please Note:

- The above ones are samples only.
- A resourceful teacher may add more.
- A potential student may exhibit variety.

**STATE BOARD OF TECHNICAL EDUCATION AND TRAINING, TAMIL NADU
SYLLABUS FOR DIPLOMA IN ELECTRICAL AND ELECTRONICS ENGINEERING
L-SCHEME**

Course Name : Diploma in Electrical and Electronics Engineering
 Subject Code : **23051**
 Semester : V Semester
 Subject Title : **POWER SYSTEM-I**

TEACHING AND SCHEME OF EXAMINATION

No. of weeks per Semester : 16

Subject	Instruction		Examination		
	Hours / Week	Hours / Semester	Assessment marks		
			Internal	Board Examination	Total
Power System - I	5	80	25	75	100

TOPICS AND ALLOCATION OF TIME

UNIT	TOPIC	TIME (Hours)
I	Generation of Electric Power	15
II	A.C. Transmission and HVDC Transmission	14
III	Line Insulators and Underground Cables	13
IV	Circuit Breakers and Over Voltage Protection	13
V	Protective Relays and Grounding	13
	Revision & Test	12
	TOTAL	80

RATIONALE

Energy is the basic necessity for the economic development of a country. As a matter of fact, there is a close relationship between the energy used per person and his standard of living. The greater the per capita consumption of energy in a country, the higher is the standard of living of its people. The modern society is so much dependent upon the use of electrical energy that it has become a part of our life. So to have adequate knowledge in Electrical power generation and transmission it becomes necessary to include this subject.

OBJECTIVES

To Understand

- Conventional power plants-Layout and choice of site
- Renewable energy sources and power generation
- Grid system and Economics of power generation
- A.C Transmission-Supports, conductors, Effects, Regulation and Efficiency
- H.V.D.C Transmission
- Line Insulators and underground cables
- Circuit breakers, Fuses and Lightning arresters
- Protective relays and grounding.

DRAFT SYLLABUS

23051 POWER SYSTEM - I

DETAILED SYLLABUS

Contents : Theory

Unit	Name of the Topic	Hours	Marks
I	<p>GENERATION OF ELECTRICAL POWER</p> <p>Introduction-Conventional methods of power generations - schematic arrangement and choice of site for Hydel,thermal,Nuclear power plants-Advantages and Disadvantages-comparison of these power plants.- Principle and types of co generation.</p> <p>Schematic arrangement of Diesel, Gas, geothermal, pumped storage schemes-Advantages and Disadvantages-</p> <p>Renewable Energy sources- Basic principle of Solar,Wind, Geothermal, Ocean, Biomass and Tidal Energy sources.</p> <p>Grid or Inter connected system-Advantages of Inter connected systems- Load Transfer through Inter connector-Load curves and Load duration curves-connected load-Average load-Maximum Demand Factor- Plant capacity factor-Load factor and its significance-Diversity factor-Load sharing between base load and peakload plants-Load Despatching centre stand-alone system</p> <p>Economics of power Generation-cost of Electrical energy and its expressions-Tariff-Types of tariff-problems in cost of generation and tariff - causes of Low power factor-Disadvantages of Low power factor-Economics of power factor improvement.</p>	15	15
II	<p>A.C TRANSMISSION AND HVDC TRANSMISSION</p> <p>A.C. Transmission:</p> <p>Introduction-Typical layout of A.C. Power supply scheme various system of power Transmission-Advantages and Disadvantages of A.C Transmission- High Transmission Voltage-Advantages-Economic choice of Transmission voltage-Elements of a Transmission Line-Economic choice of conductor size-Kelvin's Law- Its limitation-over Head Line-Conductor materials and their properties-Line supports-its properties-Types of supports and their applications-spacing between conductors-length of span-Sag in over head lines-Calculation of Sag-When the supports are at equal and unequal levels- Effect of wind and ice loading over the line conductor - Problems-constants of a Transmission line- Transposition of Transmission lines-Skin Effect-Ferranti Effect-Corona- formation and coronaloss-Factors affecting corona-Advantages and Disadvantages-Classification of O.H. Transmission lines- performance of single phase short Transmission line - voltage regulation and Transmission Efficiency-Problems.</p>	14	15

Unit	Name of the Topic	Hours	Marks
II	<p>H.V.D.C Transmission:</p> <p>Advantages and Disadvantages of D.C Transmission-Layout Scheme and principle of High Voltage D.C Transmission-D.C link configurations (monopolar, Bipolar and Homopolar)-HVDC convertor Station(Schematic diagram only)-Comparison between constant current and constant voltage HVDC systems.</p>		
III	<p>LINE INSULATORS AND UNDERGROUND CABLES</p> <p>Line Insulators:</p> <p>Introduction-Line Insulator materials-Properties of Insulators-Types-causes of failure of Insulators-Testing of Insulators-Potential Distribution over suspension Insulator string-String Efficiency - methods of improving string Efficiency- problems.</p> <p>Underground cables:</p> <p>Introduction-Advantages and requirement of cables-construction- of a three core cable-Insulating materials for cables- properties of Insulating materials used in cables-classification of cables-cables for three phase service-construction of Belted cable, screened cable, Pressure cables-Laying of under ground cables-Direct laying,Draw-in-system, solid system- Advantages and Disadvantages-Grading of cables- capacitance grading, Inter sheath grading (No derivation and Problems)-cable faults-O.C, S.C and Earth faults- Murray loop test for fault location.</p>	13	15
IV	<p>CIRCUIT BREAKERS AND OVER VOLTAGE PROTECTION</p> <p>Switch gear-Essential features of Switch gear-faults in a Power system (definition only).</p> <p>Circuit Breakers</p> <p>Basic principle of circuit Breaker -Arc Phenomenon-methods of Arc extinction-Arc voltage -Restriking voltage and recovery voltage-Rate of rise of restriking voltage-current chopping-Interruption of capacitive current -resistance switching-C.B ratings - Breaking capacity, making capacity, short time rating - Auto reclosing in circuit Breakers - Classification of C.B.S - construction, working principle , merits and Demerits of Air Blast C.B, SF6 and vacuum C.B-Maintenance schedule for circuit breakers.</p> <p>D.C breaking -Problems of D.C breaking-Schematic for HVDC C.B-producing current zero.</p> <p>Fuses-Desirable characteristics-Fuse Element materials-current rating of fuse elements-fusing current-Cut off current-L.V fuses-Rewirable fuse, HRC cartridge fuse, HRC fuse with tripping device -H.V. fuses-cartridge type, liquid type and metal clad-fuses-Comparison of fuse and circuit breaker.</p>	13	15

Unit	Name of the Topic	Hours	Marks
IV	<p>Over voltage protection:</p> <p>Voltage surge- causes of over voltage-Lightning-Types of lightning strokes -Direct stroke, Indirect stroke-Harmful Effects of lightning - Protection against lightning-Earthing screen, Overhead ground wires, Lightning arresters- Expulsion type, Gapless arrester.</p>		
V	<p>PROTECTIVE RELAYS AND GROUNDING</p> <p>Protective relays:</p> <p>Basic principled-Fundamental requirements of protective relaying- Primary and back up Protection-relay characteristics-relay timing - Instantaneous relay -Inverse time relay and Definite time lag relay- Inverse definite minimum time relay- classification of relays-Construction, Principle of operation and applications of Induction type over current relay (Directional and Non-directional), Distance relay, Differential relay, Negative sequence relay, Induction type reverse power relay, Earth leakage relay, Static relays- Basic elements of static relay - Schematic diagram and operating principle of smart protective relays - current, Impedance, directional, reactance and Mho relays.</p> <p>Grounding:</p> <p>Introduction-Equipment grounding-system grounding-ungrounded Neutral system-Necessity of Neutral grounding -methods-solid grounding, Resistance grounding Reactance grounding, Resonant grounding-Earthing Transformer.</p>	13	15

TEXT BOOK

Sl.No.	Name of the Book	Author	Publisher	Edition
1	Principles of Power	V.K.Mehta,	S. Chand & Co, New Delhi	Reprint 2007

REFERENCE BOOK

Sl.No.	Name of the Book	Author	Publisher
1	Electrical Power System	CL Wadhawa	New Age International, New Delhi (Fourth Edition, 2000)
2	A Course in Electrical Power	Soni, Gupta	Dhanpath Rai &Co (P) Ltd, New Delhi
3	Electrical Power	S.L Uppal,	Khanna Publishers, New Delhi
4	A Course in Electrical Power	J.B. Gupta,	Kaison Publishing House (Reprint 2004)
5	HVDC Power Transmission System & Technology	KR. Padiyar,	New Age International, New Delhi (Reprint 2005)
6	Electrical Power System Planning	A.S.Pabla,	MacMillan India Ltd, New Delhi
7	Digital Protection – Protective Relaying from Electromechanical to Microprocessor	LP Singh	New Age International (Second Edition 1997)
8	Power System Protection and Switchgear	B Ram & DN Viswakarma,)	TMH 1995 (Reprint 2000)

MODEL QUESTION PAPER – 1

Time: 3 Hrs

Max. Marks: 75

- Note: (i) Part 'A' Questions carry 1 mark each and answer for any 15 questions.
(ii) Part 'B' questions carry 12 marks each and answer all questions by selecting 'either' or 'OR'

PART 'A'

1. What are the conventional sources to generate Electrical power?
2. What is the purpose of surge tank?
3. Give any two disadvantages of hydroelectric power plant.
4. What is meant by stand-alone system?
5. List the elements of a transmission line.
6. Give any two limitations of Kelvin's law.
7. Give the types of line supports.
8. Write the span lengths allowable for R.C.C. Poles.
9. What is skin effect?
10. Name the types of Insulators.
11. Give any four reasons for failure of Insulators.
12. Give any three properties of Insulating materials used in cables.
13. Name the methods of laying underground cable
14. What is switch gear?
15. What are the factors responsible for the maintenance of arc between the contacts?
16. Give any three advantages of SF6 circuit breaker.
17. What is the function of a fuse?
18. What is static relay?
19. What is meant by Primary protection?
20. What is meant by grounding?

PART 'B'

- 21 a. Draw and explain the schematic arrangement of thermal power plant
(OR)
b. List and explain the advantages of interconnected system.
- 22 a. Derive an expression for the sag in a transmission line conductor suspended between two supports at the same level.
(OR)
b. Explain how to find the regulation and efficiency of short transmission lines.
- 23 a.1. Bring out the reasons for the failure of Insulator.
2. Explain any two methods to improve the string efficiency.
(OR)
b.1. Explain the construction of belted cable
2. Explain capacitance grading of U.G. Cables
24. a. Explain the construction and working principle of sulphur hexa fluoride circuit breaker and state its advantages.
(OR)
b. Explain the construction and working of HRC fuse with tripping device
25. a. Explain the construction and working principle of earth leakage relay
(OR)
b. With necessary diagram explain resistance grounding.

MODEL QUESTION PAPER – 2

Time: 3 Hrs

Max. Marks: 75

- Note: (i) Part 'A' Questions carry 1 mark each and answer for any 15 questions.
(ii) Part 'B' questions carry 12 marks each and answer all questions by selecting 'either' A or B*

PART 'A'

1. Give the renewable energy sources for generating Electrical power.
2. What is meant by grid?
3. What is meant by Tariff?
4. State Kelvin's law
5. Give the properties of conductor materials used for O.H. transmission
6. What is ferranti effect?
7. Give any two advantages of suspension Insulators.
8. What is string efficiency?
9. Name the types of pressure cable.
10. Name the types of grading of cables.
11. What is symmetrical faults in power system?
12. What is meant by Recovery voltage?
13. What is short time rating?
14. Write the desirable characteristics of fuse.
15. List the fundamental requirements of relay
16. What is meant by backup protection?
17. List the types of Neutral grounding
18. Give the types of static relays.
19. List the effects of ungrounded Neutral.
20. What is static relay?

PART 'B'

21 a. Draw and explain the schematic diagram of nuclear power plant.

(OR)

b. A generating station has a maximum demand of 50 mw. Given the following data, calculate the cost per unit delivered. Capital cost – Rs. 95×10^5 . Annual cost of fuel and oil Rs. 9×10^5 Taxes, wages and salaries – Rs. 6×10^5 Rate of Interest and depreciation – 10% Annual Load factor -50%

22 a. State and explain Kelvin's law

(OR)

b. Compare constant current and constant voltage HVDC systems

23 a. Explain the various methods of testing of insulators.

(OR)

b. Explain different types of laying of cables.

24 a. Explain the construction and working principle of vacuum Circuit breaker

(OR)

b. Explain the construction and working of expulsion type lightning arrester.

25 a. Explain the construction and working principles of directional over current relay.

(OR)

b. Explain the construction and working principle of Earthing transformer

**STATE BOARD OF TECHNICAL EDUCATION AND TRAINING, TAMIL NADU
SYLLABUS FOR DIPLOMA IN ELECTRICAL AND ELECTRONICS ENGINEERING
L-SCHEME**

Course Name : Diploma in Electrical and Electronics Engineering
 Subject Code : **24052**
 Semester : V Semester
 Subject Title : **MICROCONTROLLER**

TEACHING AND SCHEME OF EXAMINATION

No. of weeks per Semester : 16

Subject	Instruction		Examination		
	Hours / Week	Hours / Semester	Assessment marks		
			Internal	Board Examination	Total
MICROCONTROLLER	5	80	25	75	100

TOPICS AND ALLOCATION OF TIME

UNIT	TOPIC	TIME (Hours)
I	Architecture & Instruction set of 8051	16
II	Programming Examples	12
III	I/O and Timer	14
IV	Interrupt and Serial Communication.	14
V	Interfacing Techniques.	16
	Revision and Test	8
	Total	80

RATIONALE

Controlling all the machineries are realized through Electronics. Without Electronics controlling the machines, devices, systems are not possible. Microcontroller is the most reliable, cost effective and flexible for all control activities. It plays major role in Machines, domestic gadgets, automobiles etc. Here is an attempt to introduce the familiar Intel 8051 microcontroller with some programming examples.

OBJECTIVES

On completion of the following units of syllabus contents, the students must be able to

- .. Explain Architecture of 8051 Microcontroller.
- .. Explain the functions of various registers.
- .. Understand interrupt structure of 8051.
- .. Understand serial data communication concepts.
- .. Understand the programming techniques.
- .. Explain various addressing modes.
- .. Write simple programs using 8051.
- .. Understand the block diagram and control word formats for peripheral devices.
- .. Understand how to interface with RS232C.
- .. Understand how to interface with 8255.
- .. Understand various application of 8051 Microcontroller

24052 MICROCONTROLLER DETAILED SYLLABUS

Contents : Theory

Unit	Name of the Topic	Hours	Marks
I	Architecture & Instruction set of 8051: Comparison of Microprocessor and Microcontroller - Block diagram of Microcontroller –Functions of each block. Pin details of 8051 – ALU –ROM – RAM – Memory Organization of 8051 - Special function registers – Program Counter – PSW register – Stack - I/O Ports – Timer – Interrupt – Serial Port – Oscillator and Clock - Clock Cycle – State - Machine Cycle – Instruction cycle – Reset – Power on Reset – Overview of 8051 family Instruction set of 8051 – Classification of 8051 Instructions - Data transfer instructions — Arithmetic Instructions – Logical instructions –Branching instructions – Bit Manipulation Instructions.	16	15
II	Programming Examples : Assembling and running an 8051 program –Structure of Assembly Language –Assembler directives - Different addressing modes of 8051 – Programmes – Multibyte Addition – 8 Bit Multiplication and Division – Biggest Number / Smallest Number – Ascending order / Descending order – BCD TO HEX Conversion – HEX TO BCD Conversion –HEX TO ASCII Conversion – ASCII TO Binary Conversion – Square Root of a Given Number – LCM – GCD – Odd Parity Generator – Even Parity Generator - Time delay routines	12	15
III	I/O and Timer : Bit addresses for I/O and RAM – I/O programming – I/O bit manipulation programming – Programming 8051 Timers – Timer 0 and Timer 1 registers – Different modes of Timer – Mode 0 Programming – Mode 1 Programming - Mode 2 Programming - Mode 3 Programming - Counter programming – Different modes of Counter – Mode 0 Programming – Mode 1 Programming - Mode 2 Programming - Mode 3 Programming.	14	15
Unit	Name of the Topic	Hours	Marks
IV	Interrupt and Serial Communication: Basics of Serial programming – RS 232 Standards - 8051 connection to RS 232 – 8051 Serial Communication Programming – Programming the 8051 to transfer data serially - i Programming the 8051 to Receive data serially – 8051 Interrupts – Programming Timer Interrupts – Programming external hardware interrupts – Programming the serial communication interrupt – Interrupt priority in 8051	14	15
V	Interfacing Techniques : IC 8255 – Block Diagram – Modes of 8255 - IC 8253 – Block Diagram – Modes of 8253 - Interfacing external memory to 8051– 8051 interfacing with the 8255 – (Programs are to be written in Assembly for the following interfacing applications) Relays and opto isolators – Sensor interfacing – ADC interfacing – DAC interfacing - Keyboard interfacing – Seven segment LED Display Interfacing - LCD display interfacing – Stepper Motor interfacing – DC motor interfacing - PWM – DS12887 RTC Interfacing.	16	15

TEXT BOOK

Sl.No.	Name of the Book	Author	Publisher
1	8051 Microcontroller by	Kenneth J.Ayala.	

REFERENCE BOOKS

Sl.No.	Name of the Book	Author	Publisher
1	Microcontrollers, Principles and Applications	Ajit pal	PHI Ltd 2011.
2	8051 Microcontroller and Embedded Systems using Assembly and C	Mazidi, Mazidi and D.MacKinlay,	Pearson Education Low Price Edition 2006

DRAFT SYLLABUS

24052 - MICROCONTROLLER

Model question paper – I

Time : 3 Hrs.

Marks: 75

Max.

Part – A

15x1=15

Note : Answer any 15 Questions. – All Questions carry equal marks

1. What is Microcontroller?
2. Mention the number of bytes in internal RAM and internal ROM of 8051?
3. State any two differences between microprocessor and microcontroller.
4. When 8051 is reset, all interrupts are disabled. How to enable these interrupts?
5. What are the instructions used to access external RAM.
6. List the Addressing modes in 8051?
7. What is meant by assembler directives?
8. List any four assembler directives.
9. Calculate the reload value of timer 1 for achieving a baud rate of 4800 in 8051 for a crystal frequency of 11.0592 MHz.
10. Mention the timers of 8051.
11. Mention the operating modes of 8051 timers
12. Mention the control registers related to timer/counters of 8051
13. How will you double the baud rate in 8051?
14. List the interrupts available in 8051?
15. What is meant by interrupt priority in 8051?
16. What is the function of SMOD bit in PCON register?
17. Write the BSR control words to set PC0 and to reset PC4 in 8255.
18. What is the instruction used to transfer a data byte between microcontroller and 8255.
19. Define a stepper motor.
20. Give the normal 4 step sequence.

Part – B

5x12 = 60

**Note : i) Answer all Questions choosing.
ii) All sub divisions carry equal marks.**

21 A) Draw and explain the block Diagram of 8051 microcontroller

(Or)

B) i) List the special function registers with their addresses and explain any one of them

ii) Draw and explain the Structure of Internal RAM of 8051

22 A) Write an assembly language program to arrange the given set of 'n' numbers in ascending order

(Or)

B) Explain the various addressing modes in 8051 with examples.

23 A) Explain in details about the programming of 8051 timer

(Or)

B) Write a program to generate square wave of 50 Hz frequency on pin P1.2 using timer 0 interrupt.

Assume crystal = 11.0592 MHz

24 A) Explain about the programming of 8051 serial port

(Or)

B) Explain the functions of each bit of Serial Control Register (SCON) and Power Control Register (PCON) in detail.

25 A) Explain about 8051 interfacing with 8255

(Or)

B) Explain about stepper motor interfacing with 8051

24052 - MICROCONTROLLER
Model question paper – II

Time : 3 Hrs.

Max. Marks: 75

Part – A

15x1=15

Note : Answer any 15 Questions. – All Questions carry equal marks

1. Give the PSW setting for masking register bank 2 as default register bank in 8051 Microcontroller?
2. Define the clock cycle of 8051.
3. Define the machine cycle of 8051.
4. Define the instruction cycle of 8051.
5. How can you perform multiplication using 8051 Microcontroller?
6. What is the operation carried out when 8051 executes the instruction `MOVC A, @A + DPTR`?
7. Write a delay routine for 1 millisecond using timer 0 of 8051 for 12 MHz crystal frequency.
8. List the addressing modes of 8051.
9. What is the function of C/T bit of TMOD register?
10. Find the timer's clock frequency for the crystal frequency of 11.0592 MHz
11. What is the function of C/T bit of TMOD register?
12. State the function of timer flag TF in TCON register.
13. List the serial modes. ?
14. What is the function of REN bit in SCON register?
15. What is the function of SMOD bit in PCON register?
16. State the two methods of serial data communication.
17. Define a transducer.
18. Define step angle.
19. What is meant by signal conditioning?
20. Define DAC.

Part – B

5x12 = 60

**Note: i) Answer all Questions choosing.
ii) All sub divisions carry equal marks.**

- 21 A) Explain with neat sketch memory organisation of 8051.
(Or)
B) Draw the pin diagram of 8051 and explain the function of each pin.
- 22 A) Write an assembly language program (ALP) for multi-byte addition
(Or)
B) Write an ALP for finding maximum number in an array.
- 23 A) Explain the TMOD register and TCON register
(Or)
B) Explain the steps to program the timer in mode 1 and mode 2.
- 24 A) Write the steps involved in programming 8051 to transfer and receive data serially.
(Or)
B) Explain the interrupt priority in 8051.
- 25 A) Explain ADC interfacing with 8051.
(Or)
B) Explain seven segment LED display interfacing with 8051.

**STATE BOARD OF TECHNICAL EDUCATION AND TRAINING, TAMIL NADU
SYLLABUS FOR DIPLOMA IN ELECTRICAL AND ELECTRONICS ENGINEERING
L-SCHEME**

Course Name : Diploma in Electrical and Electronics Engineering
Subject Code : **23053**
Semester : V Semester
Subject Title : **SPECIAL ELECTRICAL MACHINES**

TEACHING AND SCHEME OF EXAMINATION

No. of weeks per Semester : 16

Subject	Instruction		Examination		
	Hours / Week	Hours / Semester	Assessment marks		
			Internal	Board Examination	Total
SPECIAL ELECTRICAL MACHINES	5	80	25	75	100

TOPICS AND ALLOCATION OF TIME

UNIT	TOPIC	TIME (Hours)
I	Thyristor family, trigger and commutation circuits	14
II	Phase controlled rectifiers	14
III	Choppers and Inverters	14
IV	Control of DC Drives	13
V	Control of AC Drives	13
	Revision/Test	12
	Total	80

RATIONALE

For a long time, the conventional electrical machines are being taught. Large number of special type electrical machines were developed. They are different from the conventional machines in terms of design, energy efficiency, size, performance etc. They are largely used in the industrial environment. In order to impart some knowledge on these machines, this subject is introduced.

OBJECTIVES

- To review the fundamental concepts of permanent magnets and the operation of permanent magnet brushless DC motors.
- To introduce the concepts of permanent magnet brushless synchronous motors and synchronous reluctance motors.

- To develop the control methods and operating principles of switched reluctance motors.
- To introduce the concepts of stepper motors and its applications.
- To understand the basic concepts of other special machines.

DRAFT SYLLABUS

23053 SPECIAL ELECTRICAL MACHINES

DETAILED SYLLABUS

Contents : Theory

Unit	Name of the Topic	Hours	Marks
I	PERMANENT MAGNET SYNCHROUNOUS MOTORS Principle of operation – EMF and Torque equations - Phasor diagram - Power controllers – Torque speed characteristics – Digital controllers – Constructional features, operating principle and characteristics of synchronous reluctance motor.	14	15
II	SWITCHED RELUCTANCE MOTORS Constructional features –Principle of operation- Torque prediction – Characteristics- Power controllers – Control of SRM drive- Sensorless operation of SRM – Applications.	14	15
III	STEPPER MOTORS Constructional features –Principle of operation –Types – Torque predictions – Linear and Non-linear analysis – Characteristics – Drive circuits – Closed loop control – Applications.	14	15
IV	PERMANENT MAGNET BRUSHLESS DC MOTORS Fundamentals of Permanent Magnets- Types- Principle of operation- Magnetic circuit analysis-EMF and Torque equations- Characteristics and control	13	15
V	OTHER SPECIAL MACHINES Principle of operation and characteristics of Hysteresis motor – AC series motors – Linear motor – Permanent magnet DC and AC motors, Applications.	13	15

TEXT BOOKS

Sl No	Title	Author(s)	Publishers	Edition & year
1	Brushless magnet and Reluctance motor drives	T.J.E. Miller	Clarendon press London	1989
2	Switched Reluctance motor drives	R.Krishnan	CRC press	2001
3	Stepping motors and their microprocessor controls	T.Kenjo,	Oxford University press, New Delhi	2000.

REFERENCE BOOKS

Sl No	Title	Author(s)	Publishers	Edition & year
1	Permanent magnet and Brushless DC motors	T.Kenjo and S.Nagamori	Clarendon press, London	1988
2	Electric motor drives	R.Krishnan	Prentice hall of India	2002
3	Electric machines	D.P.Kothari and I.J.Nagrath	Tata Mc Graw hill publishing company	Third Edition 2004
4	Electric Machinery and Transformers	Irving L.Kosow	Pearson Education	Second Edition 2007

DRAFT SYLLABUS

**STATE BOARD OF TECHNICAL EDUCATION AND TRAINING, TAMIL NADU
SYLLABUS FOR DIPLOMA IN ELECTRICAL AND ELECTRONICS ENGINEERING
L-SCHEME**

Course Name : Diploma in Electrical and Electronics Engineering
 Subject Code : **23071**
 Semester : V Semester
 Subject Title : **Control of Electrical Machines**

TEACHING AND SCHEME OF EXAMINATION

No. of weeks per Semester : 16

Subject	Instruction		Examination		
	Hours / Week	Hours / Semester	Assessment marks		
			Internal	Board Examination	Total
Control of Electrical Machines	5	80	25	75	100

TOPICS AND ALLOCATION OF TIME

UNIT	TOPIC	TIME (Hours)
I	Control Circuit Components	14
II	DC Motor Control Circuits	13
III	AC Motor Control Circuits	14
IV	Programmable Logic Controller	13
V	Industrial Control Circuits	14
	Revision and Test	12
	Total	80

RATIONALE

Various control operations are to be performed on the electrical machines to suit the industrial requirements. Technician are mainly employed to look after the control panels. To make our students employable, they have to be trained in using various control components and circuits. This subject fulfils that requirement.

OBJECTIVES

To understand

- Electrical control circuit elements including various types of industrial switches, relays, timers, solenoids, contactors and interlocking arrangement.
- DC motor control circuits for acceleration control, speed control, direction control, braking control and jogging using contactors.
- AC motor control circuits for acceleration control, speed control, direction control, braking control and jogging using contactors.
- Basics of programmable logic controller.
- Different control circuits for industrial applications.

DRAFT SYLLABUS

**23071 CONTROL OF ELECTRICAL MACHINES
DETAILED SYLLABUS**

Contents : Theory

Unit	Name of the Topic	Hours	Marks
I	Control Circuit Components Switches – Push button, selector, drum, limit, pressure, temperature (Thermostat), float, zero speed and Proximity switches. Relays – Voltage relay, dc series current relay, frequency response relay, latching relay and phase failure relay (single phasing preventer). Over current relay – Bimetallic thermal over load relay and Magnetic dash pot oil filled relay. Timer – Thermal, Pneumatic and Electronic Timer. Solenoid Valve, Solenoid type contactor (Air Break Contactor), Solid State Relay, Simple ON-OFF motor control circuit, Remote control operation and interlocking of drives.	14	15
II	DC Motor Control Circuits Current limit acceleration starters – Series relay and counter EMF starters - Definite Time acceleration starters – Field failure protection circuit – field acceleration protection circuit – field deceleration circuit. Jogging control, dynamic braking control, reversing control and plugging control circuits, Speed control using UJT&SCR.	13	15
III	AC Motor Control Circuits Motor current at start and during acceleration – No load speed and final speed of motor – DOL starter – Automatic auto transformer starter (open circuit and closed circuit transition) – Star/Delta starter (semi automatic and automatic) – Starter for two speed, two winding motor – Reversing the direction of rotation of induction motor – Plug stopping of the motor – Dynamic braking – Three step rotor resistance starter for wound induction motor – Secondary frequency acceleration starter.	14	15
IV	Programmable Logic Controller PLC –Definition – Requirements of PLC – Advantages over relay logic – components of PLC – Programming the PLC – Program loader – How the PLC operates – Additional capabilities of PLC – Ladder logic diagram – Symbols for common logic and sequence components in a ladder diagram – Ladder logic diagram for DOL starter, star/delta starter and fluid filling operation – Typical low level language instruction set for a PLC – Input module (schematic and wiring diagram), – Output module(schematic and wiring diagram) – PLC scan.	13	15
V	Industrial Control Circuits Planner machine – Contactor control circuit – Logic control circuit – Skip hoist control – Automatic control of a water pump – Control of electric oven – Control of air compressor – Control of over head crane – Control of conveyor system – Control of elevator – Trouble spots in control circuits – General procedure for trouble shooting.	14	15

TEXT BOOK

Sl.No.	Name of the Book	Author	Publisher
1.	Control of Electrical Machines.	S.K. Bhattacharya	New Age International Publishers, New Delhi
2.	Explosion Programmable Logic controllers with application.	Pradeep Kumar Srivastava.	BPB Publications

DRAFT SYLLABUS

CONTROL OF ELECTRICAL MACHINES (ELECTIVE THEORY I)

MODEL QUESTION PAPER I

Time: 3 hours

Marks: 75

Note: Part A questions carry each 1 mark and answer any Fifteen questions.

Part B questions carry each 12 marks and answer all questions by selecting either "a" or "b".

Part- A

01. State some relays used in the control circuit.
02. What is ON delay timer?
03. State the advantage of solid state relay.
04. What is the purpose of zero speed switch?
05. Define the term current limit acceleration.
06. What is the necessity for field acceleration protection circuit?
07. What are the precautions to be taken for D.C. motor reversing control?
08. What is meant by inching?
09. What is closed circuit transition?
10. Draw the control circuit for DOL starter.
11. What is plug stopping?
12. Draw the current speed characteristics of an AC motor during acceleration.
13. Define PLC.
14. What are the requirements of PLC
15. What are the additional capabilities of PLC?
16. Define PLC scan.
17. What is planer machine?
18. State any one of the method of heat control of oven.
19. Name any two trouble spots in a control circuit.
20. How do you reverse the direction of rotation of a three phase induction motor?

Part-B

21. a) 1) Explain the constructional details of solenoid type Contactor with a neat sketch. (6)
- 2) Draw the schematic diagram of solid state relay. (6)

OR

- b) 1) What is single phasing? What are the effects of single phasing. (6)
- 2) Explain with circuit diagram the principle of operation of single phasing preventer. (6)

- 22) a) 1) Explain the principle of dynamic braking on d.c. motor. (6)
- 2) Explain with a neat diagram the speed control of D.C motor using Diac and SCR. (6)

OR

- b) Draw and explain the control circuit of definite time acceleration starter with field failure protection and field acceleration protection arrangements. (12)

- 23) a) Explain the operation with a control circuit how dynamic Braking is done in cage induction motor. (12)

OR

- b) Explain with a control circuit the working of a automatic 3 stepped rotor resistance starter for wound rotor Induction motor. (12)

- 24) a) 1) What are the advantages of PLC over relay logic. (6)
- 2) Develop a ladder logic diagram for star Delta starter and explain. (6)

OR

- b) Draw the block diagram of PLC system and explain the Input/ output module with schematic diagram (12)

- 25) a) Explain the control circuit of Skip hoist with neat sketch (12)

OR

- b) Explain with a neat sketch, the control of a conveyor system by sequential starting of conveyor motors. (12)

CONTROL OF ELECTRICAL MACHINES (ELECTIVE THEORY I)
MODEL QUESTION PAPER II

Time: 3 hours

Marks: 75

Note: Part A questions carry each 1 mark and answer any Fifteen questions.

Part B questions carry each 12 marks and answer all questions by selecting either "a" or "b".

Part- A

01. What is float switch?
02. What is OFF Delay timer?
03. What is relay?
04. State the use of bimetallic strip.
05. Define definite time acceleration.
06. What is plugging?
07. Define Jogging.
08. How will you reverse the direction of rotation of a DC Motor?
09. What is meant by dynamic braking?
10. Define open circuit transition.
11. Which motor is started by using secondary frequency acceleration starter.
12. Mention the starter which is suitable for starting a 3 HP 3 phase IM.
13. Define Input module.
14. What are the applications of PLC?
15. Draw the block diagram of PLC.
16. What is program loader?
17. Which switch is used in automatic control of over head pressure tank?
18. How variation in temperature is achieved in electric oven?
19. What is the function of pressure switch in air compressor?
20. Which switch is used to stop the lift at different floors?

PART-B

21. a) 1) Explain the following: (i) Electronic timer (ii) zero speed switch. (6)
2) Draw the control circuit of electrical interlock and mechanical interlock and explain briefly. (6)

OR

- b) 1) Draw a neat sketch of Pneumatic timer and explain principle of operation. (6)
2) Explain in detail about frequency response relay. (6)

- 22) a) Explain with a neat diagram, the working of counter EMF starter. (12)

OR

- b) 1) Explain with neat circuit diagram the speed control Circuit using UJT and SCR? (6)
2) Draw the field acceleration protection control circuit. (6)

- 23) a) Draw the two speed two winding control circuit of an induction motor and explain. (12)

OR

- b) Draw the control circuit for auto transformer starter of closed circuit transition and explain. (12)

- 24) a) Develop ladder logic diagram for star-delta starter and explain the working. (12)

OR

- b) 1) Briefly explain the various processes carried out in a PLC scan with neat sketches. (6)
2) Name the different methods of programming a PLC and explain any one method. (6)

- 25) a) Draw and explain the logic control circuit of a Planner machine. (12)

OR

- b) With neat sketch, explain the operation of automatic control of air compressor. (12)

**STATE BOARD OF TECHNICAL EDUCATION AND TRAINING, TAMIL NADU
SYLLABUS FOR DIPLOMA IN ELECTRICAL AND ELECTRONICS ENGINEERING
L-SCHEME**

Course Name : Diploma in Electrical and Electronics Engineering
 Subject Code : **23072**
 Semester : V Semester
 Subject Title : **PROGRAMMABLE LOGIC CONTROLLER (Elective – I)**

TEACHING AND SCHEME OF EXAMINATION

No. of weeks per Semester : 16

Subject	Instruction		Examination		
	Hours / Week	Hours / Semester	Assessment marks		
			Internal	Board Examination	Total
PROGRAMMABLE LOGIC CONTROLLER	5	80	25	75	100

TOPICS AND ALLOCATION OF TIME

UNIT	TOPIC	TIME (Hours)
I	Introduction to Programmable Logic Controller	12
II	Input and Output Modules	14
III	PLC Programming	14
IV	Networking	14
V	Data Acquisition Systems	14
	Revision and Test	12
	Total	80

RATIONALE

Industries are going for automation to reduce their product cost to sustain their market among customers. Industrial automation with newer technology reduces human presence for any process. It leverages different electronic equipments to control different parameter of any industrial process. Programmable logic controllers plays an important role in industrial automation. There are wide scope for diploma holders in installation, testing and maintenance of PLC based automatic process control industries.

OBJECTIVES

To understand

- Evolution, internal structure, interface modules, advantages and market available PLCs.
- Various types of input and output modules.
- Input sensors.
- Various PLC programming methods, basic instructions like ON, OFF, timer, counter, latched and unlatched outputs.
- Simple PLC ladder programs for starters, filling plants.
- PLC networking, industrial standard communication networks.
- SCADA system hardware and software.

DRAFT SYLLABUS

23072 PROGRAMMABLE LOGIC CONTROLLER

DETAILED SYLLABUS

Contents : Theory

Unit	Name of the Topic	Hours	Marks
I	<p>Introduction to Programmable Logic Controller</p> <p>PLC evolution – hardwire control system compared with PLC system - advantages of PLCs – criteria for selection of suitable PLC - Block diagram of PLC – principle of operation – CPU – memory organization – I/O modules – Input types – Logic, Analog – pulse train – expansion modules – power supplies to PLC – modular PLCs - list of various PLCs available</p>	12	15
II	<p>Input and Output Modules</p> <p>Input Modules</p> <p>Discrete input module – AC input module – DC input module – sinking and sourcing – sensor input – special input modules – Sensors – limit switch, reed switch, photo electric sensor, inductive proximity sensor – Input Addressing scheme in important commercial PLCs.</p> <p>Output modules</p> <p>Discrete output module – TTL output module – Relay output – Isolated output module – surge suppression in output – Analog outputs – open collector output. Output Addressing scheme in important commercial PLCs.</p>	14	15
III	<p>PLC Programming</p> <p>Symbols used – relays and logic functions – OR, AND, Comparator - Programming Devices – programming methods – STL and CSF, FBD and Ladder methods – simple instructions – Programming NC and NO contacts - EXAMINE ON and EXAMINE OFF instructions - online, offline methods– Latch and Unlatch outputs – pulse edge evaluation – timer instructions – on-delay and off-delay timer. Counter instructions – UP / DOWN counters – Timer and Counter applications. Program control instructions – Data manipulating instructions – Math instructions. converting simple relay ladder diagram into PLC relay ladder diagram – PID and PWM functions. Sample PLC implementations for Automatic Star-Delta Starter and 4 - floor Lift system.</p>	14	15
IV	<p>Networking</p> <p>Levels of industrial control – types of networking – network communications – principles – transmission media – Field Bus – introduction, concepts, international field bus standards – Networking with TCP / IP Protocol – Network architecture – Physical addressing – LAN technologies – Ethernet – Token Ring – Sub-netting – subnet mask – transport layer – ports – sockets network services – file transfer protocol.</p>	14	15
V	<p>Data Acquisition Systems</p> <p>Computers in Process control – Data Loggers – Data acquisition systems (DAS) – Alarms – Direct Digital Control (DDC) - Characteristics of digital data – Controller software – Computer Process interface for Data Acquisition and control –Supervisory Digital Control (SCADA) -introduction and brief history of SCADA – SCADA Hardware and software</p>	14	15

TEXT BOOK

Title	Author(s)	Publishers	Edition
Introduction to Programmable Logic Controller	Gary Dunning	Thomson Delmar learning	

REFERENCE BOOKS

Sl.No	Title	Author(s)	Publishers	Edition
1	Programmable Logic Controllers; Principles and applications	Jhon W Webb Ronald A Rels	PHI LearningPvt Ltd	2012
2	Exploring Programmable Logic Controllers with applications	Srivastava	BPB Publishers	2012
3	Programmable Logic Controllers	Vijay R Yadhav	Khanna Publishers	
4	Programmable Logic Controllers; Principles and applications	NIIT	NIIT	2010

MODEL QUESTION PAPER I

Time – Three hours

Maximum Marks : 75

- [N.B – 1. Answer any 15 questions from Part A Each Question carries 1 mark.
2. Answer all questions in part B choosing either (A) OR (B) in each Question. Each Question in part B carries 12 Marks.

Part A

1. State the use of PLC.
2. List the various types of PLC.
3. What is the function of analog input module?
4. Draw the symbol of Float switch
5. List the four major parts of PLC
6. State the purpose of input output interface.
7. Mention the output address scheme of Siemens Micro PLC
8. List the various types of input devices connected with a PLC
9. Draw the symbol for PLC comparator
10. When NO contact becomes NC contact in a relay.
11. List the different types of programming methods of PLC
12. State the uses of counter in a PLC
13. Mention some transmission media.
14. Which field bus is required with distributed control system?
15. What is communication protocol?
16. What are the classification of network.
17. Expand DAS .
18. Expand SCADA .
19. Write any two advantage of SCADA.
20. Write about Direct Digital Controller

Part B

21. A) Discuss in detail about advantages of PLC over hardwired system.
(or)
B) Draw the basic block diagram of PLC and give brief account on each block.
22. A) Draw the discrete input module and explain the operation.
(or)
B) Discuss in detail about various output module of PLC.
23. A) Explain ON delay and OFF delay timer instructions with simple examples.
(or)
B) Develop relay logic diagram of star delta starter and convert it into logic diagram
24. A) Draw a typical architecture of industrial control system showing field bus and explain?
(Or)
B) Give a note on: i) Ethernet ii) Transport layer
25. A) What do you understand by DAS. Discuss its function with simple real time example.
(or)
B) Discuss in detail about SCADA software.

**PROGRAMMABLE LOGIC CONTROLLER
MODEL QUESTION PAPER II**

Time – Three hours

Maximum Marks : 75

- [N.B – 1. Answer any 15 questions from Part A Each Question carries 1 mark.
2. Answer all questions in part B choosing either (A) OR (B) in each Question. Each Question in part B carries 12 Marks.

Part A

- 1 . List some standard PLCs available in market..
2. Mention the function of CPU in PLC.
- 3 What is the function of analog output module?
4. What are types of IC Memory used in PLC?
5. Draw the symbol of limit switch.
6. Name the component in isolation section
7. List the various types of output devices connected with a PLC
8. State the advantages of photo electric sensors
9. Mention the different types of timer values.
10. Which function is needed for process control instrumentation?.
11. What are the commonly used timers?
12. What is input scan?
13. Mention any two international field bus standard
14. What is the necessity of file transfer protocol?
15. What are the requirements of field bus?
16. What is the function of transport layer?
17. State the uses of data acquisition system.
18. Expand SCADA.
19. What do you understand by data logging?
20. State two characteristics of digital data controller.

Part B

- 21 A) Discuss in detail about PLC operation.
(or)
B) Explain the memory organization of standard PLCs
22. A) Discuss about AC input module.
(or)
B) Draw the discrete output module and explain the operation.
23. A) What are the counting operation available in standard PLCs? Explain them.
(or)
B) Develop ladder logic control for 4 floor lift system and explain.
24. A) Discuss about various layers in Communication protocol
(or)
B) Give a note on: Field level communication protocol.
25. A) Explain the operation of a Data acquisition systems with a generalized block diagram
(or)
B) What do you understand by SCADA system? Give a brief account on it

**STATE BOARD OF TECHNICAL EDUCATION AND TRAINING, TAMIL NADU
SYLLABUS FOR DIPLOMA IN ELECTRICAL AND ELECTRONICS ENGINEERING
L-SCHEME**

Course Name : Diploma in Electrical and Electronics Engineering
 Subject Code : **23073**
 Semester : V Semester
 Subject Title : **ELECTRICAL MACHINE DESIGN (ELECTIVE THEORY – 1)**

TEACHING AND SCHEME OF EXAMINATION

No. of weeks per Semester : 16

Subject	Instruction		Examination		
	Hours / Week	Hours / Semester	Assessment marks		
			Internal	Board Examination	Total
ELECTRICAL MACHINE DESIGN (ELECTIVE THEORY – 1)	5	80	25	75	100

TOPICS AND ALLOCATION OF TIME

UNIT	TOPIC	TIME (Hours)
I	Electrical Machine Design – Basic Consideration	12
II	Magnetic Circuit Calculations	12
III	Design of Transformer	14
IV	Design of dc machines	14
V	Design of ac machines	16
	Tests and Revisions for above Units	12
	Total	80

RATIONALE

Through out the country there are many electrical industries and manufacturing different kinds of electrical machines like transformers, DC generators, DC motors, AC motors, and alternators. Their rating starts from hundreds of WATTS / VA to few KW / KVA or even in MW / MVA. These Industries have R&D center, Diploma or Graduate engineers as R&D engineers for product development. Hence it is necessary to include electrical machine design as one of the subject at diploma level courses.

OBJECTIVES

To understand

- Static and Rotating Electrical Machine specifications, materials, losses and effects of temperature rise.
- Magnetic force, magnetic force gap, teeth and leakage flux in static and rotating electrical machines.
- Designing of single phase, three phase transformer, core and coil.
- Designing of dc machines.
- Designing of 3phase induction motor and 3phase synchronous machines.

DRAFT SYLLABUS

23073 ELECTRICAL MACHINE DESIGN (ELECTIVE THEORY – 1)

DETAILED SYLLABUS

Contents : Theory

Unit	Name of the Topic	Hours	Marks
I	Electrical Machine Design – Basic Consideration Design definition – Design consideration – limitation – constructional elements of Transformers and rotating machines – constructional materials of electrical machines – conducting magnetic and insulating materials standard specification – general design process – main dimensions of rotating machines – electrical and magnetic losses – temperature – rise – class of duty – limits of temperature rise.	12	15
II	Magnetic Circuit Calculations Magnetic circuits of DC machines, round rotation AC machines, salient poles AC machines and Transformer - Specific magnetic and electrical loading – Factor influencing the specific and magnetic loading – Magnetic leakages – magnetizing curves – calculation of magnetizing force for the air gap of rotating machines and for teeth – leakage flux – leakage reactance – armature slot leakage reactance	12	15
III	Design of Transformer Important considerations – core and shell types – distribution transformers and power transformers – core section – clearance – yoke section – main dimension – single phase core type transformers – three phase core type transformer – output coefficient - voltage per turn – specific magnetic and electric loading of transformer – Winding design – cross over, helix, disc helix.	14	15
IV	Design of dc machines Important design consideration – number of poles – advantages of large number of poles - air gap – armature slot – current density – field system – commutator – design of large dc motor. Specific magnetic and electric loading of dc machines.	14	15
V	Design of ac machines AC machine design consideration – power equation – separation of diameter and length – problems. Three phase induction motor – important design consideration – standard frames and stampings – gap length – flux density – current density – power factor – efficiency – slot combination –winding - design of 3 phase induction motors. Three phase synchronous machines – important design consideration – radial gap length – stator slot – stator coil – rotor construction – design of 3 phase synchronous machines.	16	15

TEXT BOOK

Title	Author(s)	Publishers	Edition
Course in electrical machine design	A.K.Sawhney	Dhanrai publishing company	

REFERENCE BOOKS

Sl.No	Title	Author(s)	Publishers	Edition
1	principles of Electrical Machine Design	S.K.Sen	Oxford & IBH	
2	Principles of Electrical Machine Design	R.K.Agarwal	S.K.Kataria & Sons	
3	Design of Electrical Machine	Mittle V.N	Standard Book – House	
4	Electrical Machine Design	A.Nagoor Kani	RBA Publications	
5	Electrical Machine Design	C.Eswarlal	Sonaversity	
6	Performance and Design of AC Machine	M.G.Say	CBS Publisher & Distributor	

DRAFT SYLLABUS

**ELECTRICAL MACHINE DESIGN (ELECTIVE THEORY I)
MODEL QUESTION PAPER I**

Part-A

**Answer Any 15 Questions out of 20 given Questions
One Mark for Each question**

1. List important specification of a DC machine
2. In which transformer Oil deteriorates faster.
3. Which shaft type is generally used in Water wheel generators.
4. What do you understand by the term continuous rating ?
5. Define leakage coefficient.
6. Mention the factors that affect the voltage regulation transformer and rotating machines.
7. In which machines, the air gap is minimum along the direct axis and increases as the pole tip is approached.
8. What are the effects of leakage flux in electrical machines.
9. Why power transformers are designed to have maximum efficiency at or near full load
10. Mention the factors that affect the voltage regulation in transformer
11. Why distribution transformers are designed to have low leakage reactance
12. State the use of Distribution transformers.
13. Define specific magnetic loading.
14. What are the important considerations in selecting no of poles in DC machine?
15. Write the formula for the frequency of flux reversal in armature.
16. Mention the current density of small wire wound armature.
17. Why die-cast aluminum rotor bars are employed?
18. What is the effect of using a large air gap on the performance of an induction motor?
19. Mention the type of air gap in Turbo alternator.
20. State the factor that governs Diameter in ac machines.

Part-B

**Answer either (A) or (B) of each Questions
12 Mark for Each question**

21. A) What are the important design and construction elements of a transformer? Discuss about them.

(or)

B) Discuss in detail about magnetic materials used for machine design.
22. A) Explain in detail about rotating machine leakage reactance.

(or)

B) Discuss about magnetizing force for teeth.
23. A) Estimate the main dimensions including winding conductor area of a 3-phase, Δ -Y core type transformer rated at 300 kVA, 6600/440 V, 50Hz. A suitable core with 3-steps having a circumscribing circle of 0.25 m diameter and a leg spacing of 0.4 is available. Emf per turn = 8.5V, $\delta = 2.5$ A/mm², $K_w = 0.28$, $S_f = 0.9$ (stacking factor).

(or)

B) Discuss about helix type transformer winding.
24. A) Arrive the power equation of dc generator and dc motor.

(or)

B) Enumerate the advantages of large number of poles in dc machine.
25. A) Mention the important design considerations of 3 phase induction motor and discuss about them.

(or)

B) Determine approximate values for the stator bore and the effective core length of a

55 KW, 415 V, three phase, star connected, 50 Hz four pole induction motor. Efficiency = 90% ; power factor = 0.91; winding factor = 0.955. Assume suitable data wherever necessary.

ELECTRICAL MACHINE DESIGN (ELECTIVE THEORY I) MODEL QUESTION PAPER II

Part-A

Answer ANY 15 Questions out of 20 given Questions

One Mark for Each question

1. What happens to resistivity of steel when silicon is added.
2. State two types of major classification of machine duty.
3. Compare the conducting property of copper and aluminum.
4. What is the function of core in electrical machines?
5. Define specific magnetic loading.
6. Mention the two components of armature leakage flux.
7. Define specific electrical loading.
8. What are parts of magnetic circuit in a rotating machine.
9. Which ducts are used in core for cooling purpose for number of steps 6 and above.
10. Why distribution transformers are designed to have maximum efficiency at loads quite lower than full load
11. What is window space factor.
12. Name the different types of windings used in transformers.
13. Which material is used for commutator?
14. Write average flux density in dc machine.
15. Why the brushes of machine are made of carbon?
16. List some of the advantages of choosing large number of poles in dc machine.
17. Write the value of the gap density of induction motor for general purpose.
18. Which type of construction is suitable for large motor?
19. Discuss the factor that determine the chose of air gap in an induction motor.
20. In which machines, the air gap is minimum along the direct axis and increases as the pole tip is approached.

Part-B

Answer either (A) or (B) of each Questions

12 Mark for Each question

21. A) What are the important design and construction elements of rotating machines? Discuss about them.
(or)
B) Enumerate the component losses in a transformer and rotating machine.
22. A) Discuss about magnetizing force for teeth.
(or)
B) Explain in detail about transformer leakage reactance.
23. A) Derive the power equation of 1 phase core type transformer.
(or)
B) Show that for minimum total I² loss in a transformer, current densities of primary and secondary should be approximately equal.
24. A) Find the main dimensions of a 200kw, 250V, 6 pole, 1000 rpm generator. The maximum value of flux density in the gap is 0.87 Wb/m² and the ampere conductors per meter of armature periphery are 31000. The ratio of pole arc to pitch is 0.67 and the efficiency is 91 percent. Assume the ratio of length of core to pole pitch =0.75.
(or)
B) What are the considerations to be taken into account in the choice of number and

dimensions of slots for a dc machine? Discuss about them.

25. A) Derive the power equation of ac generator and motor.

(or)

B) Mention the important design considerations of 3 phase synchronous machines and discuss about them.

DRAFT SYLLABUS

**STATE BOARD OF TECHNICAL EDUCATION AND TRAINING, TAMIL NADU
SYLLABUS FOR DIPLOMA IN ELECTRICAL AND ELECTRONICS ENGINEERING
L-SCHEME**

Course Name : Diploma in Electrical and Electronics Engineering
Subject Code : **23055**
Semester : V Semester
Subject Title : **ELECTRICAL CIRCUITS SIMULATION PRACTICAL**

TEACHING AND SCHEME OF EXAMINATION

No. of weeks per Semester : 16

Subject	Instruction		Examination		
	Hours / Week	Hours / Semester	Assessment marks		
			Internal	Board Examination	Total
Electrical Circuits Simulation Practical	5	80	25	75	100

RATIONALE

All the Engineering applications are simulated through computers. They are tested and then built using real components for commercial implementation. Simulation softwares are available for all Engineering fields. Hers is an attempt to impart the knowledge of using simulation software for realizing some of the Electrical and Electronics circuits for the Diploma students.

OBJECTIVES

On completion of this practical subject, the students will be able to

- Know the various aspects of a simulation software
- Simulate and test the simple electrical and electronics circuits
- Simulate and test the wave generating circuits
- Simulate and prove the simple theorems
- Simulate and test the performance characteristics of converters
- To design and verify the results of various electric circuits using simulation software (MATLAB)

23055 ELECTRICAL CIRCUITS SIMULATION PRACTICAL

DETAILED SYLLABUS

Contents : Practical

List of Experiments

- (1) Square wave generation
- (2) Sawtooth wave generation
- (3) Triangular wave generation
- (4) Sign wave generation
- (5) Step response of RL & RC series circuits
- (6) Verification of superposition theorem
- (7) Verification of Norton's theorem
- (8) Verification of Thevenin's theorem
- (9) Simulation of half wave rectifier
- (10) Simulation of full wave rectifier
- (11) Simulation of single phase, half wave converter using SCR with R-load
- (12) Simulation of single phase, semi converter with RL load
- (13) Simulation of single phase full converter with RL load
- (14) Simulation of 6 step Voltage Source Inverter supplying R-load

S.No	LIST OF EQUIPMENTS	Quantity Required
1	PC – Pentium Dual Core	30
2	MATLAB 7.5 - Multi user	1
3	UPS 5KVA with half an Hour battery back up	1

Allocation of Marks

Circuit Diagram (Manual Drawing)	– 20 Marks
Development & Simulation	– 35 Marks
Print out	– 10 Marks
Viva	– 10 Marks
Total	– 75 Marks

**STATE BOARD OF TECHNICAL EDUCATION AND TRAINING, TAMIL NADU
SYLLABUS FOR DIPLOMA IN ELECTRICAL AND ELECTRONICS ENGINEERING
L-SCHEME**

Course Name : Diploma in Electrical and Electronics Engineering
Subject Code : **24055**
Semester : V Semester
Subject Title : **MICROCONTROLLER PRACTICAL**

TEACHING AND SCHEME OF EXAMINATION

No. of weeks per Semester : 16

Subject	Instruction		Examination		
	Hours / Week	Hours / Semester	Assessment marks		
			Internal	Board Examination	Total
MICROCONTROLLER PRACTICAL	5	80	25	75	100

RATIONALE

Controlling all the machineries are realized through Electronics. Without Electronics controlling the machines, devices, systems are not possible. Microcontroller is the most reliable, cost effective and flexible for all control activities. It plays major role in Machines, domestic gadgets, automobiles etc. Here is an attempt to impart practical skill to use the familiar Intel 8051 microcontroller for some simple applications.

OBJECTIVES

On completion of the following units of syllabus contents, the students must be able to

- .. Use micro controller kits for simple applications
- .. programme the 8051 controller to do simple arithmetic and logical operations
- .. Understand serial data communication concepts.
- .. Understand how to interface the devices
- .. To use microcontroller for simple control applications

24055 MICROCONTROLLER PRACTICAL

DETAILED SYLLABUS

Contents : Practical

List of Experiments

PROGRAMMING EXPERIMENTS

Minimum 12 Experiments are to be conducted

1. Introduction of Microcontroller Kit
2. Addition, Subtraction
3. Multi-byte addition
4. Multiplication and Division of two numbers
5. Finding the maximum value in an array
6. Arranging the given data in Ascending order
7. BCD to Hex conversion
8. Hex to BCD conversion
9. Hex to ASCII
10. ASCII to Binary
11. Square Root of an given number
12. Least Common Multiple
13. Greatest Common Divisor
14. Parity bit generation
15. Program using I/Os in port 1
16. Program using timer / Counter.
17. Program using interrupt

INTERFACING WITH APPLICATION BOARDS

Minimum Six Experiments are to be conducted

1. Digital I/O
2. Matrix keyboard
3. Seven segment LED displays
4. . LCD Displays
5. . Traffic light
6. . 8 bit ADC and 8 bit DAC
- 7 . STEPPER MOTOR CONTROL
- 8 . DC motor control
- 9 . Lift control
10. Sending data through serial port between controller kits
11. Printer Interfacing with Microcontroller kit

Equipments Required

1	8051 Microcontroller Kit	18
2	Digital I/O Interface Board	1
3	3. Matrix keyboard Interface Board	1
4	Seven segment LED display Interface Board	1
5	LCD Display Interface Board	1
6	. Traffic light Interface Board	1
7	8 bit ADC and 8 bit DAC Interface Board	1
8	STEPPER MOTOR CONTROL Interface Board	1
9	DC motor control Interface Board	1
11	Lift control Interface Board	1
12	Sending data through serial port between controller kits	1
13	Printer Interface Interface Board.	1

**STATE BOARD OF TECHNICAL EDUCATION AND TRAINING, TAMIL NADU
SYLLABUS FOR DIPLOMA IN ELECTRICAL AND ELECTRONICS ENGINEERING
L-SCHEME**

Course Name : Diploma in Electrical and Electronics Engineering
Subject Code : **23074**
Semester : V Semester
Subject Title : **Control of Electrical Machines Practical**

TEACHING AND SCHEME OF EXAMINATION

No. of weeks per Semester : 16

Subject	Instruction		Examination		
	Hours / Week	Hours / Semester	Assessment marks		
			Internal	Board Examination	Total
Control of Electrical Machines Practical	5	80	25	75	100

RATIONALE

Various control operations are to be performed on the electrical machines to suit the industrial requirements. Technician are mainly employed to look after the control panels. To make our students employable, they have to be trained in using various control components and circuits. This subject fulfils that requirement.

OBJECTIVES

On completion of this practical subject the students will be able to

- Make use of various types of control circuit elements like industrial switches, relays, timers, solenoids, contactors and interlocking arrangement.
- Construct various types of automatic starters for electrical motors
- Construct control circuits for braking, jogging, reversing operations
- To make use of PLCs for control applications
- To program PLCs for controlling the motors

23074 CONTROL OF ELECTRICAL MACHINES PRACTICAL

List of Experiments

- (1) Perform breakdown test and determine the dielectric strength of transformer oil
- (2) Conduct acidity test on transformer oil
- (3) Test the timing characteristic of thermal overload relay
- (4) Wire and test the control circuit for jogging in cage motor
- (5) Wire and test the control circuit for semi-automatic star-delta starter
- (6) Wire and test the control circuit for automatic star-delta starter
- (7) Wire and test the control circuit for dynamic braking of cage motor
- (8) Wire and test the control circuit for two speed pole changing motor
- (9) Wire and test the control circuit for automatic Rotor resistance starter
- (10) Conduct test on speed control of DC motor using SCR
- (11) Test the working of single phase preventer
- (12) Wire and test the DOL starter using PLC
- (13) Wire and test the Star-Delta starter using PLC
- (14) Wire and test the control circuit for jogging, forward and reverse operations using PLC
- (15) Wire and test the single phase preventer using PLC
- (16) Wire and test the control circuit for automatic Rotor resistance starter using PLC

CONTROL OF ELECTRICAL MACHINES PRACTICAL

S.No	LIST OF EQUIPMENTS	Quantity Required
1	Transformer oil Tester Kit	1
2	Acidity test kit	1
3	Thermal Overload Relay Tester	1
4	Control circuit for Jogging of 3 phase IM	1
5	Control Circuit for Semi-automatic Star –delta Starter	1
6	Control circuit for Automatic star-delta starter	1
7	Control circuit for dynamic braking of cage motor	1
8	control circuit for two speed pole changing motor	1
9	control circuit for automatic Rotor resistance starter	1
10	Speed control of DC motor using SCR	1
11	control circuit for single phase preventer	1
12	control circuit for DOL starter using PLC	1
13	control circuit for Star-Delta starter using PLC	1
14	Control circuit for jogging, forward and reverse operations using PLC	1
15	Control circuit for single phase preventer using PLC	1
16	Control circuit rotor resistance starter using PLC	1
17	PLC	2

Scheme of Evaluation

SI No.	Activity of the Candidate	Maximum Marks to be awarded
1	Drawing Correct Diagram and writing Details of the Components/Equipments/Machines used	15
2	Making the correct circuit connections	15
3	Conducting the Experiment - Following the correct procedure - Taking the appropriate readings - Following the appropriate safety procedure	25
4	Tabulation of Readings Interpretatin of Results Graphical Representation (if required)	15
5	Viva-voce (Questions related to the given experiments only)	5
	Total Marks (External)	75

**STATE BOARD OF TECHNICAL EDUCATION AND TRAINING, TAMIL NADU
SYLLABUS FOR DIPLOMA IN ELECTRICAL AND ELECTRONICS ENGINEERING
L-SCHEME**

Course Name : Diploma in Electrical and Electronics Engineering
Subject Code : **23075**
Semester : V Semester
Subject Title : Programmable Logic Controller Practical

TEACHING AND SCHEME OF EXAMINATION

No. of weeks per Semester : 16

Subject	Instruction		Examination		
	Hours / Week	Hours / Semester	Assessment marks		
			Internal	Board Examination	Total
Programmable Logic Controller Practical	5	80	25	75	100

23075 PROGRAMMABLE LOGIC CONTROLLER PRACTICAL

List of Experiments

- (1) DOL Starter with single phasing prevention
- (2) Changeover switch implementation with interlocking
- (3) Star Delta starter
 - single phasing prevention
 - Adjustable star-delta transfer time
 - Pre-settable Overload trip time
- (4) Automatic Load transfer
 - transfers load from one phase to another when one phase in a 3
 - ph. system fails
 - automatically restores when power is resumed
 - time delays are effected to prevent action during short time failure
- (5) Industrial sliding door automation
 - Sequencing
 - Open ¼ th Full width
 - Wait for next go command
 - Next open full
 - wait for a time and close full

(6) Fire Alarm

- Multiple alarms
- sound alarm 1
- if not acknowledged, sound alarms 1 and 2
- similarly go upto 4 alarms

(7) Conveyor Belt sorting

- storing to left bin
- storing to right bin
- storing to exit bin

(8) Three floor Hoist controller

- Sequencing
- floor level detection
- Gate safety latch

(9) Burglar scare random lighting in building with variable timing

- The lights in each room are switched on at pre-determined intervals and switched off at pre-determined time. The lighting is shifted from area to area randomly to scare the burglars with a false fear of presence of people.

(10) Analog input to PLC as a set of value for a comparator function block

- The output is multilevel illumination control. The input setting is by means of a potentiometer in an analog input to the PLC. The outputs turn on several groups of lamps to obtain desired level of illumination.

(11) Heater control with PID function of the PLC

- A 1000 W water heater is controlled using the PID function of the PLC. The temperature transducer is a Temperature transmitter with 4 to 20 mA output and Pt 100 Probe

(12) Round Table - Liquid filling System

Dropping of Reagents into test tubes. The feedback is from a potentiometer. The program must ensure that the end limits of the pot are never reached by carefully balancing the clockwise and anti-clockwise revolution.

(13) Sequential timer for educational institute

Timings are alterable by supervisor while program is running. Pre and-post – Holiday sequence selectable

(14) PC monitoring of PLC operation. RS232 or USB communication for status display of inputs and outputs..

- (15) Slow speed motor control using PWM function of the PLC
- Slow speed 12V DC 18W Permanent Magnet Motor with a fly wheel is controlled with the PWM output and a feedback from a low resolution encoder
- (16) Testing of RC snubber component for protection of PLC output from a highly inductive components like solenoids or relays.

List of equipments

SI.No	Name of the equipments	Quantity
1	PLC with suitable No of I/O (various brands, Computer interface cables software etc)	5
2	Push button switch limit switch, reed switch, photo electric sensor, inductive proximity sensor Capacitive proximity sensor	5 Each
3	PLC Power supply (SMPS if necessary)	Required No
4	DOL Starter	2No
5	440V, 16A Contactor 3P,2NO+2NC	5 No
6	440V, 16A Contactor 4P,2NO+2NC	2No
7	230V, 16A Contactor 3P,2NO+2NC	5NO
8	Industrial sliding door automation model	1 No
9	Conveyor Belt sorting model	1 No
19	Three floor Hoist controller model	1 No
11	Analog input to PLC (Addon blocks if needed)	1 No
12	LAMP LOAD for Burglar scare random lighting in building with variable timing	1 No
13	Heater control with PID function of the PLC- 1000 W water heater with accessories	1 No
14	Round Table - Liquid filling System (simple model)	
15	Electric bell (230V Operation)	2 NO
16	Slow speed 12V DC, Low Watt Permanent Magnet Motor	1No

**STATE BOARD OF TECHNICAL EDUCATION AND TRAINING, TAMIL NADU
SYLLABUS FOR DIPLOMA IN ELECTRICAL AND ELECTRONICS ENGINEERING
L-SCHEME**

Course Name : Diploma in Electrical and Electronics Engineering
 Subject Code : **23076**
 Semester : V Semester
 Subject Title : **Electrical Machine Design Practical**

TEACHING AND SCHEME OF EXAMINATION

No. of weeks per Semester : 16

Subject	Instruction		Examination		
	Hours / Week	Hours / Semester	Assessment marks		
			Internal	Board Examination	Total
Electrical Machine Design Practical	5	80	25	75	100

23076 ELECTRICAL MACHINE DESIGN PRACTICAL (Elective practical I)

List of Experiments

1. By simple experiment, verify the magnetic laws using Coil, permanent magnet and Galvanometer.
2. Verify the rotating magnetic field with stator and ball.
3. Measure magnetic flux using flux meter.
4. Using Crawler test the windings.
5. Design a 1 phase 1 KVA, 230/15V core type transformer and assemble the core.
6. Design a 1 phase 1KVA, 230/15V shell type transformer and assemble the core.
7. Design 3 phase 1 KVA transformer and assemble winding, core, etc.,
8. Design 3 phase 1 KVA transformer (delta/star connected) and wind one coil set.
9. Design armature for 5 KWdc machine and insert one coil set.
10. Design field pole for 5 KWdc machine and assemble one pole and insert in the body.
11. Assemble the given dc machine (pole, inter pole, armature, commutator, brush etc).
12. Design and assemble ceiling fan.
13. Design and assemble a 3 HP induction motor.
14. Design and assembled 3phase 3HP synchronous motor.
15. Dismantle and assemble a 3 phase wound rotor induction motor.
16. Design and assembled 1phasesalient pole 5KVA alternator.

23076 ELECTRICAL MACHINE DESIGN PRACTICAL (Elective practical II)

List of Equipments Required

1. Permanent Magnets	-	2 Nos
2. Galvanometers	-	2Nos
3. Flux meter	-	1No
4. Growler	-	1No
5. 3Phase induction motor stator with winding	-	1No
6. 1KVA Single phase 230/15 loading Transformer	-	1No
7. 1KVA 3 phase Transformers	-	3Nos
(or)		
E & I type stampings for 1KVA Transformer	-	12Kg
Primary Coils & Secondary Coils for 1KVA Transformer	-	9Nos
8. 5KW DC armature without winding	-	1No
9. 5KW DC machine with inter poles	-	2Nos
10. Stator with winding, rotor and end covers with bearing of a 3HP cage induction motor	-	2sets
11. 5KVA Single phase alternator	-	1No
12. 3phase 3HP wound rotor induction motor	-	2Nos
13. Ceiling Fans	-	2Nos
14. Motor coil winding machines	-	2Nos

Allocation of Marks

For exercises requiring circuit diagram and connection

1. Circuit Diagram	-	20marks
2. Connection	-	20marks
3. Readings Taken & Tabulation	-	10marks
4. Calculation & Result and Graph if any	-	20marks
5. Viva	-	5marks

Total - 75marks

For other exercises

1. Design Particulars / Theory behind exercises	-	30marks
2. work menship & finishing / carrying of the test & finding the result	-	40marks
3. Viva	-	5marks

STATE BOARD OF TECHNICAL EDUCATION AND TRAINING, TAMIL NADU
SYLLABUS FOR DIPLOMA IN ELECTRICAL AND ELECTRONICS ENGINEERING
L-SCHEME

Course Name : Diploma in Electrical and Electronics Engineering
 Subject Code : **23061**
 Semester : VI Semester
 Subject Title : Power System - II

TEACHING AND SCHEME OF EXAMINATION

No. of weeks per Semester : 16

Subject	Instruction		Examination		
	Hours / Week	Hours / Semester	Assessment marks		
			Internal	Board Examination	Total
Power System - II	6	96	25	75	100

TOPICS AND ALLOCATION OF TIME

UNIT	TOPIC	TIME (Hours)
I	Distribution	18
II	Industrial Drives	16
III	Electric Traction	16
IV	Illumination	18
V	Electric Heating & Welding	16
	Revision & Test	12
	TOTAL	96

RATIONALE

Distribution system is that part of power system which distributes power to the consumers for utilisation. So to have adequate knowledge in distribution and utilization of Electrical energy it becomes necessary to include this subject.

OBJECTIVES

To Understand

- Substation arrangements
- Distribution -classification and scheme of connection
- Drives-Suitability for different applications
- Track Electrification-Traction mechanics
- Traction motors and control
- Illumination -Design of lighting scheme-sources of light
- Electric Heating- Different methods.
- Electric furnaces and Temperature control
- Electric welding and welding equipments

**23061 POWER SYSTEM - II
DETAILED SYLLABUS**

Contents : Theory

Unit	Name of the Topic	Hours	Marks
I	<p>DISTRIBUTION</p> <p>Substation: Introduction-Sub stations-classification of sub stations-Indoor and out door S.S - Gas insulated S.S-comparisions-Layout 110/11KV Sub station and 11KV/400V Distribution Substation- sub station equipments-Busbar- Types of busbar arrangement -Advantages and Disadvantages.</p> <p>Distribution: Distribution system-Requirements of a Distribution system-parts of Distribution system-Classification of Distribution systems-comparison of different distribution systems (A.C and D.C) -A.C Distribution - Types-connection schemes of Distribution system-A.C Distribution calculations-Calculation of voltage at load points on single phase distribution systems (With concentrated load only)- Distribution fed at one end, both ends and ring mains-problems- Three phase, four wire, Star connected unbalanced load circuit- Problems-consequence of Disconnection of Neutral in three phase four wire system (illustration with an example)</p>	18	15
II	<p>UNIT II - INDUSTRIAL DRIVES</p> <p>Introduction-Electric drive- Advantages-parts of Electric drives-Transmission of power-Types of Electric drives-Individual, group and multimotor drives - Advantages and disadvantages of Individual and group drive -Factors governing the selection of motors-Nature and classification of load Torque-Matching of speed Torque characteristics of load and motor-Standard ratings of motor- classes of load duty cycles-Selection of motors for different duty cycles-Selection of motors for specific application-Braking- Features of good braking system-Types of Braking-Advantages of- Electric braking-Plugging,Dynamic and Regenerative braking-As applied to various motors.</p>	16	15
III	<p>ELECTRIC TRACTION</p> <p>Introduction-Traction systems-Advantages and Disadvantages of Electric Traction.</p> <p>System of Track Electrification: Methods of supplying power-Rail connected system and over head system-O.H. equipments-contact wire, catenary and droppers- current collection gear for OHE-Bow and pantograph collector-Different systems of Track Electrification-Advantages of singlephase low frequency A.C. system-Booster Transformer-Necessity- Methods of connecting B.T-Neutral sectioning.</p> <p>Traction Mechanics: Units and notations used in Traction mechanics-Speed time curve for different services - simplified speed time curve-Derivation of maximum speed-crest speed, Average speed, Schedule speed (definitions only)-Tractive effort and power requirement- Specific energy output- specific energy consumption.</p>	16	15

Unit	Name of the Topic	Hours	Marks
	<p>Traction motors and control: Desirable characteristics of Traction motors-Motors used for Traction purpose-Methods of starting and speed control of D.C Traction motors-Rheostatic Control-energy saving with plain rheostatic control- series-parallel control- Energy saving with series parallel starting - Shunt Transition -Bridge-Transition- Drum control-contactor type bridge Transition controller - Metadyne control-multiple unit control -Regenerative braking.</p> <p>Recent trends in Electric Traction-Magnetic Levitation (MEGLEV)- Suspension systems</p>		
IV	<p>ILLUMINATION Introduction - Definition and units of different terms used in illumination-plane Angle, Solids angle, Light,. Luminous flux, Luminous Intensity, Luminous Efficacy candle power, Lumen, Illumination, M.S.C.P, M.H.C.P, M.H.S.C.P- Reduction factor, Luminance, glare Lamp efficiency. Space-height ratio, Depreciation factor Utilization factor, waste light factor, Absorption factor, Beam factor, Reflection factor- Requirements of good lighting system-Laws of Illumination-problems. Types of lighting scheme- Factors to be considered while designing lighting scheme- Design of lighting</p> <p>Scheme (Indoor and outdoor)- Problems- Lighting systems- Factory lighting, Flood lighting, Street lighting.</p> <p>Sources of light-Arc lamp, Incandescent lamp, Halogen Lamp, Sodium vapour lamp, High pressure mercury vapour lamp, Fluorescent Tube - Stroboscopic Effect - Energy saving lamps (C.F.L and L.E.D lamps)- - Energy saving consideration for fluorescent lamp.</p>	18	15
V	<p>ELECTRIC HEATING AND WELDING Electric Heating Introduction -Advantages of Electric heating-modes of heat transfer-classification of Electric Heating - Power frequency electric heating-Direct and Indirect resistance heating-Infrared heating-Arc heating -High frequency Electric heating-Induction heating -Eddy current heating and Dielectric heating.</p> <p>Electric furnaces: Resistance furnace-Requirements of Heating elements-commonly used heating element materials-Resistance furnace for special purposes-Temperature control of resistance furnace-Arc furnace -Direct and Indirect Arc furnace-Temperature control of Arc furnace-Reasons for employing low voltage and high current supply -Induction furnace-Direct and Indirect core type Induction furnace-coreless Induction furnace-Power supply for coreless Induction furnace.</p> <p>Electric welding: Introduction-Types of Electric welding-Requirements of good weld-Preparation of work -Resistance welding- Butt welding, Spot welding, Seam welding, Projection welding and Flash welding-Arc welding-Carbon Arc welding,metal Arc welding, Atomic hydrogen Arc welding, Inert gas metal arc welding-Comparison between Resistance and Arc welding. Radiation welding -Ultrasonic welding, Electron beam welding, LASER beam welding-Electric welding equipments (A.C. and D.C).</p>	16	15

REFERENCE BOOKS

Sl.No.	Name of the Book	Author	Publisher
1	A Course in Electrical Power	JB Gupta	Katson Publishing House, New Delhi
2	Electric Power,	SL Uppal	Khanna Publishers, New Delhi
3	A Textbook in Electric Power	Soni & Gupta,	Dhanpat Rai & Sons, Delhi
4	Modern Electric Traction	H Partab,	Dhanpat Rai & Sons, New Delhi
5	Electrical Power Distribution System	AS Pabla,	Tata McGraw Hill Publishing Co, New Delhi
6	Fundamentals of Electrical Drives	GK Bubey,	Narosa Publishing House, New Delhi
7	Utilization of Electric Power	NV Suryanarayana,	Tata McGraw Hill Publishing Co, New Delhi
8	Electric Drives	Vedam Subramaniam,	New Age International, New Delhi

MODEL QUESTION PAPER – 1

Time: 3 Hrs

Max. Marks: 75

- Note: (i) Part 'A' Questions carry 1 mark each and answer for any 15 questions.
(ii) Part 'B' questions carry 12 marks each and answer all questions by selecting 'either' or 'OR'

PART 'A'

1. What is Indoor Substation?
2. Name the types of busbar arrangement.
3. List any two advantages of Ring busbar system
4. Write the use of Instrument transformer in substation.
5. Give any two advantages of Electric drives.
6. What is multi motor drive?
7. What is continuous rating?
8. Give any two advantages of Electric braking.
9. Give any two requirements of Ideal traction system
10. What are the methods of supplying power to electric traction?
11. What is tractive effort?
12. Give any two advantages of regenerative braking
13. Define space height ratio
14. Define Depreciation factor
15. Define Illumination
16. What is stroboscopic effect?
17. Give any two advantages of Electric heating
18. What is meant by direct resistance heating?
19. Give any two requirements of heating elements
20. What are the types of Arc welding

PART 'B'

- 21 a. Diagrammatically represent the layout of a typical 110 KV / 11 KV substation with all details.
(OR)
b. Compare the volume of conductor materials required in Three phase, four wire system with D.C. two wire with one conductor earthed.
- 22 a. Explain with necessary sketch, matching of speed – Torque characteristics of load and motor.
(OR)
b. Explain how regenerative braking is applied to D.C. Series and shunt motor.
- 23 a. List the disadvantages of single phase low frequency A.C. traction system.
b. Write short notes on Pantograph collector
(OR)
c. With an illustration explain the function of Booster Transformer in traction.
d. Explain plain Rheostatic method of starting D.C. traction motors.
- 24 a. State and prove two laws of illumination
(OR)
b. Explain with a sketch working of sodium vapour lamp.
25. a. With a neat sketch explain ajax-wyatt vertical core type furnace
(OR)
b. Explain Electron beam welding

MODEL QUESTION PAPER – 2

Time: 3 Hrs

Max. Marks: 75

- Note: (i) Part 'A' Questions carry 1 mark each and answer for any 15 questions.
(ii) Part 'B' questions carry 12 marks each and answer all questions by selecting 'either' or 'OR'

PART 'A'

1. What is outdoor substation?
2. List any two advantages of double busbar arrangement.
3. Classify the distribution system based on character of service voltage
4. What is Power factor correction substation?
5. What is individual drive?
6. Name any two types of enclosures used in drives
7. What is Intermittent rating?
8. What is meant by plugging?
9. Write any two advantages of Electric Traction.
10. What is Neutral section?
11. What is adhesive weight?
12. What is the purpose of catenary in overhead equipments?
13. What is luminous efficacy?
14. What is the advantage of C.F.L. over fluorescent tube?
15. Give any two requirements of good lighting system.
16. What is meant by semi-direct lighting?
17. What is convection mode of heat transfer?
18. List any two applications of dielectric heating.
19. Give any two materials used for Heating element?
20. What type of D.C. Generator is used in welding and why?

PART 'B'

- 21 a. Draw and explain double bus bar arrangement and list its advantages
(OR)
- b. A single phase distributor has loop resistance of 0.3 ohm and a reactance of 0.4 ohm. The far end of the distributor has a load current of 80 A and power factor 0.8 lagging at 220 V. The mid-point 'C' of the distributor has a load current of 50 A at power factor 0.707 lagging with reference to voltage 'C'. Calculate the sending end voltage and power factor.
- 22 a. Explain different types of drives used in Industrial loads.
(OR)
- b. Choose the motor suitable for the following applications. Give reasons for your choice.
(i) Cement mill (ii) Belt conveyors (iii) Centrifugal pump
(iv) Lift and hoists (v) Rolling mill (vi) Paper mill
- 23 a. Derive from basic principles for the crest speed using trapezoidal speed time curve, State all your assumptions clearly with relevant units.
(OR)
- b. Explain contactor type bridge transition controller.
- 24 a. What are the requirements of good lighting system
b. Explain stroboscopic effect and how it is eliminated in fluorescent tube light.
(OR)
- c. Explain the principle of an incandescent lamp.
d. Explain the factors to be considered while designing lighting schemes.
- 25 a. Explain Dielectric heating and Eddy current heating
(OR)
- b. Write short notes on (i) butt welding (ii) Spot welding (iii) Seam welding (iv) projection welding (v) Flash welding

**STATE BOARD OF TECHNICAL EDUCATION AND TRAINING, TAMIL NADU
SYLLABUS FOR DIPLOMA IN ELECTRICAL AND ELECTRONICS ENGINEERING
L-SCHEME**

Course Name : Diploma in Electrical and Electronics Engineering
 Subject Code : **23062**
 Semester : VI Semester
 Subject Title : **ELECTRICAL ESTIMATION AND ENERGY AUDITING**

TEACHING AND SCHEME OF EXAMINATION

No. of weeks per Semester : 16

Subject	Instruction		Examination Assessment marks		
	Hours / Week	Hours / Semester	Internal	Board Examination	Total
ELECTRICAL ESTIMATION AND ENERGY AUDITING	5	80	25	75	100

TOPICS AND ALLOCATION OF TIME

UNIT	TOPIC	TIME (Hours)
I	Systems of Internal Wiring, Wire size, Fuses, Shock, Earthing and Testing of installation	14
II	Domestic, Commercial and Industrial Installation Estimate	13
III	General Aspects of Energy Auditing Squirrel Cage Motors	15
IV	Transformers and Cables	13
V	Lighting and Pumping Systems	13
	REVISION AND TEST	12
	TOTAL	80

**23062 ELECTRICAL ESTIMATION AND ENERGY AUDITING
DETAILED SYLLABUS**

Contents : Theory

Unit	Name of the Topic	Hours	Marks
1	<p>Systems of Internal Wiring, Wire size, Fuses, Shock, Earthing and Testing of installation</p> <p>Conventional symbols for various wiring items, accessories etc. A brief study of important Indian Electricity Rules (1956)</p> <p>Internal wiring, Wire size, Fuses, Shock</p> <p>Wiring systems - Types of wiring - points to be considered for selection of wiring - comparison - Looping back system and Joint box system and tree system - Position of switches, cutouts, main switch board, sub-distribution boards. Considerations for selecting wire size - size of conductors/cable used for Domestic installation, Service connection, Distributors- Power rating of some important house holds electrical appliances – selection of Fuses.</p> <p>Electric shock - Effects of electric shock - factors influencing the electric shock - Precautions against electric shock - cure of shock - Treatment for electric shock - artificial respiration - fire hazards due to electricity.</p> <p>Earthing and Testing of Installation</p> <p>Necessity - different methods - pipe earthing and plate earthing - materials required - requirements of good earth electrode neutral wire - difference between neutral wire and earth wire - connection with earth - value of earth resistance and factors on which it is dependent - points to be remembered while providing earth - ELCB system - Earthing of domestic fitting and appliances - Industrial Earthing - Substation Earthing.</p> <p>Insulation Resistance test between earth and conductor and between conductor - Leakage test - Insulation Resistance of motors and other equipment - Factors to be considered for checking electrical installations - Testing of wiring installation: introduction, verification of polarity, effectiveness of earthing, insulation resistance, earth resistance- periodical testing - testing of UG cable - Guidelines for installation of fitting switches, light, fans, earthing of appliances and electrical machines.</p>	14	15

Unit	Name of the Topic	Hours	Marks
II	<p>Domestic, Commercial and Industrial Installation Estimate</p> <p>Conditions and Requirements for Domestic, Commercial and Industrial Installation - steps to be followed in preparing electrical estimate (domestic, industrial and agricultural installation)</p> <p>Estimate the quantity of material required for</p> <p>(1) Residential single bed room Flat (1BHK). (2) Industrial power wiring having 4 or 5 machines. (3) School building having 3 class rooms. (4) Primary Health Centre having minimum 6 rooms. (5) Lighting scheme of a party hall having minimum 20 twin TL fittings. (6) Erection of one no. 15hp induction motor in Saw mill / Flour mill. (7) Irrigation Pump motor (5hp) wiring. (8) Computer centre having 10 computers, a/c unit, UPS, light and fan. (9) Street Light service having 12 lamp light fittings (10) 3 phase Service connection to a building having 5 KW load.</p>	13	15
III	<p>General Aspects of Energy Auditing</p> <p>Introduction - Types of Energy Auditing - Benefits of Energy Audit - Requirements to conduct Energy Audit - Methodology for Energy Audit - Energy Audit Report - Energy Conservation Building Code.</p> <p>Squirrel Cage Motors</p> <p>Operation of Induction Motor - Special Design feature for high efficiency motor - Torque - Speed Characteristics - Operating parameters of motor - Losses - Measurement of efficiency - Determination of energy saving - determination of Load - Assessment of economic feasibility - choice of energy efficient motor - Effect of variation of voltage on the performance of motor - effect of load variations on efficiency and power factor - unbalanced phase voltage - insulation system.</p>	15	15

Unit	Name of the Topic	Hours	Marks
IV	<p>Transformers and Cables</p> <p>Transformers Introduction - Transformer Losses - Fixed Losses - Load Losses. Evaluation of Transformer Losses - Case Studies - reduction in Transformer Losses. Energy Conservation Building Code - mandatory requirements - maximum allowable power transformer losses.</p> <p>HT and LT Cables Introduction- Selection of Cable - Construction - Insulation - inner sheath - armouring - outer sheath - specifications - Tests- Installation. Economics in selection of cables.</p>	13	15
V	<p>Lighting and Pumping Systems</p> <p>Lighting Systems Colour Rendering Index (CRI), Aspects of Lighting System Designing. Installed Load Efficacy Ratio. Various means for Energy Saving - use of natural day light - reduction in light fixture - high efficiency lamps and luminaires - effect of reduction in supply voltage - electronic ballasts - timers and occupancy sensors - Fluorescent tube lights - CFL lamps - Lighting Control - Exterior Lighting control - Interior Lighting power - Installed Interior Lighting Power - Exterior Lighting Power.</p> <p>Pumping Systems Centrifugal Pumps - Pumping System characteristics - static head vs Flow. Pump curves - pump operating point - Factors affecting pump performance - Matching pump and system head-flow characteristics - effect of over sizing the pump - energy loss in throttling. Efficient pumping system operation - effect of speed variation - effects of impeller diameter change - pump suction performance. Flow Control Strategies - pump control by varying speed - Pumps in parallel switched to meet demand- Stop/Start Control - Flow Control Valve - By-pass control - Fixed Flow reduction - Variable Frequency Drives. Energy Conservation Opportunities in Pumping Systems.</p>	13	15

TEXT BOOK

Sl No.	Title	Author(s)	Publishers	Edition	Year
1	Electrical Wiring, Estimating and Costing	Dr.S.L.Uppal.	Khanna Publishers.		
2	Electrical Design Estimating and Costing.	K.B.Raina & S.K.Battacharya.	New age international (p) limited. Publishers		
3	Energy Auditing in Electrical Utilities	Rajiv Shankar.	Viva Books	First	2010
4	ENERGY ENGINEERING AND MANAGEMENT	AMLAN CHAKRABARTI	PHI Learning Pvt Ltd	Second Printing	2011

**STATE BOARD OF TECHNICAL EDUCATION AND TRAINING, TAMIL NADU
SYLLABUS FOR DIPLOMA IN ELECTRICAL AND ELECTRONICS ENGINEERING
L-SCHEME**

Course Name : Diploma in Electrical and Electronics Engineering
 Subject Code : **23081**
 Semester : VI Semester
 Subject Title : **Power Electronics**

TEACHING AND SCHEME OF EXAMINATION

No. of weeks per Semester : 16

Subject	Instruction		Examination		
	Hours / Week	Hours / Semester	Assessment marks		
			Internal	Board Examination	Total
Power Electronics	5	80	25	75	100

TOPICS AND ALLOCATION OF TIME

UNIT	TOPIC	TIME (Hours)
I	Thyristor family, trigger and commutation circuits	14
II	Phase controlled rectifiers	14
III	Choppers and Inverters	14
IV	Control of DC Drives	13
V	Control of AC Drives	13
	Revision/Test	12
	Total	80

RATIONALE :

Developments in Electronics have their own impact in other fields of Engineering. Today all the controls and drives for the electrical machines are formed by electronic components and there are many electronic devices available to handle electric power in terms Kilo-Amps and Kilo-Volts. This subject gives a comprehensive knowledge base about the devices and circuits used in electrical power control.

OBJECTIVES:

On completion of these units, the student should be able to:

- Explain the characteristics of Thyristor family.
- Draw the SCR trigger circuits.
- Explain the working of trigger circuits.
- Draw the commutation circuits.
- Explain the operation of commutation circuits.
- Explain the principle of advanced trigger circuit using IC TCA 785.
- State the applications of trigger and commutation circuits.
- Explain the operation of microcontroller based trigger circuit.
- Familiarize the phase controlled rectifier.
- Know the applications of the phase controlled rectifier.
- Draw and describe the working of half wave controlled rectifier circuit with R and R L load.
- Draw and explain the working of single phase semi converter bridge and Single phase full Converter Bridge for RL load.
- Draw and explain the operation of single phase and three phase full converter with RL load.
- Familiarizes the dual converter.
- Familiarizes the twelve pulse converter.
- Study the complete protection of converter circuits.
- Understand the working choppers and inverters.
- Know the applications of choppers and inverters.
- Explain the various types of choppers with circuit diagram.
- Describe the various methods of inverters with circuit diagram.
- Understand the control of DC Drives.
- Know the various methods of speed control of DC drives.
- Learn the different types of power factor improvement in phase controlled Converter.
- Study the closed loop control of DC drives.
- Familiarize the control of AC drives.
- Know the torque - speed characteristics of three phase induction motor.
- Study the speed control of three phase induction motor.
- Study the speed control of three phase induction motor using micro computer based PWM.
- Understand the closed loop control of AC drive.
- Know the operation of single phase and three phase cyclo converter.
- Understand the micro controller based fault diagnosis in three phase thyristor converter circuits.
- Study the need of DSP based motor control.

**23081 POWER ELECTRONICS
DETAILED SYLLABUS**

Contents : Theory

Unit	Name of the Topic	Hours	Marks
I	<p><u>Thyristor family, trigger and commutation circuits</u> Thyristor family (Review) SCR rating and their importance - circuit, working characteristics and applications of SCR, DIAC, TRIAC, IGBT and MOSFET, only symbols of SCS, SUS, SBS, LASCR and GTO. Gate trigger circuits – Requirements – Types of triggering circuits – Pulse transformer in trigger circuits – R firing – RC firing – Synchronised UJT firing (Ramp triggering) – IC based advance triggering circuits for SCR & TRIAC (using IC TCA 785) – Microcontroller based Trigger circuits, Block diagram & flow chart. Commutation circuits – SCR turn off methods – Natural commutation – Forced commutation – class A, class B, class C, class D, class E and class F.</p>	14	15
II	<p style="text-align: center;"><u>Unit II – Phase controlled rectifiers</u></p> <p>Introduction – Application of phase controlled rectifier – Explanation of half wave controlled rectifier with resistive, Inductive loads – Effect of free wheeling diode – single phase semi converter controlled bridge with R load, RL load - single phase fully controlled bridge with RL load – Input power factor – Three phase half controlled bridge with RL load, Three phase fully controlled bridge with RL load – Single phase dual converter – Twelve pulse converter – power factor improvements, classification – Extinction angle – control of single phase converter – Reactive power of converter – Complete protection of thyristors against surge current, surge voltage, dv/dt, di/dt protection in three phase bridge circuit.</p>	14	15
III	<p><u>Choppers and Inverters</u> Choppers – Introduction – applications – principle of chopper – control strategies – chopper circuit classification – step up chopper – Morgan chopper – Jones chopper – chopper using MOSFET – DC to DC converter without Isolation, Buck, Boost, Buck Boost, Cuk converters – DC to DC converter with Isolation three configurations, Fly back, Forward, Push Pull converters. Inverters – Introduction – Applications – classifications - parallel inverter – Half bridge inverter, Full bridge inverter – Modified MC Murray full bridge inverter, MC Murray Bedford full bridge inverter – Three phase bridge inverter under 180° mode, 120° mode operations – pulse width modulated inverters, (single pulse, multiple pulse, sinusoidal pulse) UPS, online , offline - Control circuit for SMPS.</p>	14	15
IV	<p><u>Control of DC Drives</u> Introduction – History of DC drive – applications – basic DC motor speed equation – operating region – armature voltage control- field current control – constant torque and constant HP regions – circuit diagram, output waveforms and output equation of – separately excited DC motor in – a) Single phase full converter drives b) Single phase dual converter drives c) Three phase semi converter drives – power factor improvement in phase controlled converter – phase angle control – semi converter operation of fully controlled converter – Asymmetrical firing – DC chopper for series motor drive – Four quadrant control of DC Motor – DC to DC converter using MOSFET and IGBT – Block diagram, Explanations of closed loop control of DC drives - phase locked loop control of DC drives – Microprocessor</p>	13	15

	based closed loop control of DC drives.		
--	---	--	--

Unit	Name of the Topic	Hours	Marks
V	<p>Control of AC Drives</p> <p>Introduction – Applications – Torque speed characteristics of three phase induction motor – speed control of Induction Motor – Stator Voltage control – Variable frequency control – necessity of maintaining V/F ratio constant scalar and vector control of drives (Tacho) – Rotor resistance control</p> <p>Inverters for variable voltage and variable frequency control – Speed control by rotor resistance for slip ring Induction motors – Static scherbius drive (slip power recovery scheme) - closed loop control of AC drive block diagram – Micro computer based PWM control of Induction Motor – introduction to cyclo converter with simple circuit.</p> <p>Various Fault Diagnosis in Three phase thyristor converters using Micro controller – converter circuit – phase failure detecting circuit, Detection of thyristor on-off status and short circuit condition.</p> <p>ASICs for motor control applications –Need for DSP based motor control – Motor control peripherals</p>	13	15

TEXT BOOK

Sl. No.	Name of the Book	Author	Publisher
1	Power Electronics	MD Singh KB Dhanchandaniata	McGraw Hill Publishing Company New Delhi seventeenth reprint 2005

REFERENCE BOOKS

Sl. No.	Name of the Book	Author	Publisher
1	Power Electronics – Converter Applications and Design	Mohan Underland Robbins	John Wiley and Sons, NewYork 2 nd Edition
2	Fundamentals of Electrical Drives	G K Dubey	Narosa Publishing House, New Delhi Fourth reprint 2004.
3	Fundamentals of Power Electronics	S Rama Reddy	Narosa Publishing House, New Delhi, First Reprint 2002.
4	Power Electronics	Dr P S Bimhra	Khanna Phublisher- 1991
5	Power Electronics	P C Sen	Tata McGraw Hill Publishing Company New Delhi, 24 th repringy 2005
6	Power Electronics	Muhammad H.Rashid	Prentice-Hall of India Pvt. Ltd. New Delhi- 110001. 3 rd Edition-2005.
7	Power Electronics	M.S. Jamil Asghar	E.E. Edition PHI, 7 th print July 2009
8	Power Electronics Devices & Circuits	V. Jagannathan	E.E. Edition 2 nd Edition.
9	Power electronics principle and applications	Josep vithayathil	TMH edition.

POWER ELECTRONICS

Model Question Paper -1

Part A - Answer any fifteen Questions

15 x 1 = 15 Marks

1. Draw the symbol of MOS controlled Thyristor.
2. Define holding current of SCR.
3. Explain dv/dt rating.
4. What is class- B commutation?
5. What are the effects of free wheeling diode?
6. Define input power factor.
7. What is Extinction angle control of single phase converter?
8. What do you mean by complete protection of thyristor?
9. Define Chopper.
10. What are the applications of Chopper?
11. How many SCR's are used in parallel inverter?
12. What is the use of UPS?
13. Write the basic DC motor speed equation.
14. What are the advantages of power factor improvement?
15. What is the meaning of Asymmetrical firing?
16. What are the advantages of Microprocessor based DC- drive?
17. What is a Cyclo converter?
18. What are the advantages of AC drive?
19. What is the role of Microcontroller in fault diagnosis?
20. What is the abbreviation of ASIC?

Part B - Answer all the Questions

5 x 12 = 60 Marks

21. A) 1. Explain the concept of gate turn off thyristor – GTO.
2. Explain synchronized trigger circuit with waveforms.
(Or)
B) 1. With a block diagram explain the IC based advanced triggering circuits for SCR & TRIAC using TCA 785.
2. Explain the concept of Microcontroller based trigger circuit with a block diagram.
22. A) 1. Explain half wave controlled rectifier with resistive load.
2. Draw and explain the complete protection of Thyristor circuit.
(Or)
B) 1. Explain fully controlled bridge with resistive load.
2. Derive the concept of reactive power of converters.
23. A) 1. Explain MORGAN chopper with suitable circuit and waveforms.
2. Explain completely the modified MC-Murray full bridge inverter.
(Or)
A) 1. Explain CUK converter with circuit diagram.
2. Explain sinusoidal pulse width modulated inverter with suitable circuit.
24. A) 1. Explain three phase semi converter drive with waveforms.
2. Explain DC to DC converter with MOSFET circuits.
(Or)
B) 1. Explain single phase dual converter drives.
2. With block diagram explain Microprocessor based closed loop control of DC drive.
25. A) 1. Explain with circuit diagram the slip power recovery scheme.
2. Explain various fault diagnosis in three phase converter using Micro controller.
(Or)
B) 1. Explain with circuit of a single phase to single phase cycloconverter.
2. Explain the concept of ASIC's for motor control applications.

**STATE BOARD OF TECHNICAL EDUCATION AND TRAINING, TAMIL NADU
SYLLABUS FOR DIPLOMA IN ELECTRICAL AND ELECTRONICS ENGINEERING
L-SCHEME**

Course Name : Diploma in Electrical and Electronics Engineering
 Subject Code : **23082**
 Semester : VI Semester
 Subject Title : **BIO MEDICAL INSTRUMENTATION**

TEACHING AND SCHEME OF EXAMINATION

No. of weeks per Semester : 16

Subject	Instruction		Examination		
	Hours / Week	Hours / Semester	Assessment marks		
			Internal	Board Examination	Total
BIO MEDICAL INSTRUMENTATION	5	80	25	75	100

TOPICS AND ALLOCATION OF TIME

UNIT	TOPIC	TIME (Hours)
I	Physiological & Clinical Measurement	14
II	Bio - Medical Recorders	14
III	Therapeutic Instruments	14
IV	Bio – Telemetry And Patient Safety	14
V	Modern Imaging Techniques	14
	Revision/Test	10
	Total	80

RATIONALE

Recent advances in medical field have been fuelled by the instruments developed by the Electronics and Instrumentation Engineers. Pacemakers, Ultrasound Machine CAT, Medical diagnostic systems are few names which have been contributed by engineers. Now health care industry uses many instruments which are to be looked after by instrumentation engineers. This subject will enable the students to learn the basic principles of different instruments/equipment used in the health care industry. The practical work done in this area will impart skill in the use, servicing and maintenance of these instruments/equipment. Proficiency in this area will widen the knowledge and skill of diploma holders in the field of biomedical instrumentation.

OBJECTIVES

After learning this subject, the student will be able to understand about

- The generation of Bio potential and its measurement using various Electrodes.
- The measurement of Blood pressure.
- The measurement of Respiration rate.
- The principle of operation of ECG recorders
- The principle of operation of EEG & EMG recorders
- The working principle of Audio meter.
- The principle of operation of pacemakers.
- The basic principle of Dialysis.
- The principle of operation of Endoscopy.
- The working principle of telemetry.
- The basic principle of Telemedicine.
- The basic principle of various types of lasers.
- The basic principle of CT Scanners.
- The principle of operations of various Imaging techniques used in medical field.
- The various method of accident prevention

**23082 BIO MEDICAL INSTRUMENTATION
DETAILED SYLLABUS**

Contents : Theory

Unit	Name of the Topic	Hours	Marks
	PHYSIOLOGICAL & CLINICAL MEASUREMENT		
I	Elementary ideas of cell structure, heart and circulatory system, control nervous system, Musculo-skeletal system, Respiratory system Body temperature and reproduction system. Bio – potential and their generation – resting and action potential – propagation of action potential. Electrodes – Micro – Skin – surface – needle electrodes Measurement of Blood pressure (direct, indirect) – instantaneous flow (Electro magnetic flow meter, ultrasonic blood flow meter) – blood pH Measurement of Respiration rate – lung volume – heart rate – Temperature (body temperature & Skin temperature) Chromatography, Photometry, Flurometry.	14	15
	BIO - MEDICAL RECORDERS:		
II	Electro cardiograph (ECG) – Lead system – ECG electrodes – ECG amplifiers – ECG recording units – analysis of ECG curves. Nervous system – EEG recorder – 10-20 lead system – recording techniques – EEG wave types – Clinical use of EEG – brain tumour Electro – myograph (EMG) – EMG waves – measurement of conduction velocity – EMG recording techniques – Electro – retinograph (ERG) Audiometer – principle – types – Basics audiometer working	14	15
	THERAPEUTIC INSTRUMENTS:		
III	Cardiac pacemaker – classification – External pace makers – implantable pacemaker – pacing techniques – programmable pacemaker – power source of implantable pacemakers (Hg batteries, nuclear batteries, Lithium cells) Cardiac defibrillators – types – AC – DC defibrillators Heart lung machine – Oxygenators – Blood pumps – peristaltic pump – Heart valves – Problems of artificial heart valves. Dialysis – Hemo dialysis – peritoneal dialysis. Endoscopy – principle of working and applications	14	15
	BIO – TELEMETRY AND PATIENT SAFETY:		
IV	Introduction – physiological – adaptable to bio – telemetry – components of a bio telemetry system – application of telemetry in patient care – problems associated with implantable telemetry. Fluid balance – electrolytic balance – acid base balance. Physiological effects of electric current – Micro and macro shock – leakage current – shock hazards from electrical equipment. Methods of Accident Prevention – Grounding – Double Insulation – Protection by low voltage – Ground fault circuit interrupter – Isolation of patient connected parts – Isolated power distribution system. Safety aspects in electro surgical units – burns, high frequency current hazards, Explosion hazards Telemedicine – Introduction – working – applications	14	15

Unit	Name of the Topic	Hours	Marks
V	MODERN IMAGING TECHNIQUES: LASER beam properties – block diagram – operation of CO2 and NDYag LASER – applications of LASER in medicine . X ray apparatus – block diagram – operation – special techniques in X-ray imaging – Tomogram – computerized Axial tomography – Ultrasonic imaging techniques – Echo cardiography – Angiography – CT scanner - Magnetic resonance imaging techniques	14	15

REFERENCE BOOKS

Sl.No.	Name of the Book	Author	Publisher
1	Biomedical Instrumentation and measurement	Leslie Cromwell – Fred.J. Weibell,	
2	Medical Electronics	Kumara doss	
3	Medicine and Clinical Engineering	Jacobson and Webstar	
4	Handbook of Bio – Medical Instrumentation.	R. S. Khandpur	
5	Introduction to Medical Electronics.	B.R. Klin	

Model Question Paper-1

[N.B – (1) Answer any 15 questions in PART A & either (a) OR (b) of each question in PART B.

(2) Each question carries 1 (one) mark in PART A & 12 marks in PART B

PART A

1. Define action potential.
2. What is meant by respiration rate?
3. What is the use of electrodes?
4. Define pH.
5. State the purpose of RL electrode in ECG.
6. What do you mean by brain tumor.
7. What is an audiometer?
8. What is EMG test?
9. What is fibrillation?
10. Give the types of blood pump.
11. What is a cardiac pacemaker?
12. What is a hemodialyser?
13. Which tissue has less percent of water content?
14. What is fluid balance?
15. What is biotelemetry?
16. Define macro shock.
17. Mention any two properties of laser beam.
18. What is electrocardiography?
19. State the application of computerized axial tomography.
20. What is angiography?

PART B

21. A) 1. Write short notes on micro electrode.

2. Explain about the lung volume measurement.
(or)

B) 1. Discuss about direct method of blood pressure measurement.

2. Explain about chromatographic technique for analyzing various constituents present in blood samples.

22. A) 1. Analyze the waveforms obtained in ECG.

2. Explain the working of ERG with neat block diagram.
(or)

B) 1. Explain the 10-20 lead system used in EEG with neat sketch.

2. Explain about the basic block diagram of audiometer.

23. A) 1. Differentiate internal & external pacemaker.

2. Discuss about operation of heart lung machine.
(or)
- B) 1. Explain the working of dc defibrillator with a neat diagram.
2. Briefly discuss about the working of endoscopy with a neat diagram.
24. A) 1. Explain the various components of biotelemetry.
2. Explain in detail about the various methods of accident prevention.
(or)
- B) 1. Explain the physiological effects of electrical current in detail.
2. Write down the safety aspects in surgical unit.
25. A) 1. Explain the application of laser in medicine.
2. Write briefly about ultrasonic imaging technique.
(or)
- B) 1. Explain the working of a X- ray machine with block diagram.
2. Explain the basic block diagram of Magnetic Resonance Imaging technique.

**DIRECTORATE OF TECHNICAL EDUCATION
GOVERNMENT OF TAMILNADU**

L – SCHEME

(Implements from the Academic Year 2012-2013 onwards)

Course Name : Diploma in Information Technology
 Course Code : 1046
 Subject Code : 24682
 Semester : VI Semester
 Subject Title : **COMPUTER HARDWARE AND NETWORKS**

TEACHING AND SCHEME OF EXAMINATION:

No. of Weeks per Semester: 16 Weeks

Subject	Instructions		Examination			Duration
	Hours / Week	Hours / Semester	Marks			
			Internal Assessment	Board Examination	Total	
COMPUTER HARDWARE AND NETWORKS	5 Hours	80 Hours	25	75	100	3 Hours

Topics and Allocation of Hours:

Sl. No	Topics	Time (Hours)
Unit-I	MOTHERBOARD COMPONENTS AND MEMORY STORAGE DEVICES	14 Hours
Unit-II	I/O DEVICES AND INTERFACE	14 Hours
Unit-III	TROUBLE SHOOTING OF DESKTOP AND LAPTOPS	14 Hours
Unit-IV	COMPUTER NETWORK DEVICES AND OSI LAYERS	14 Hours
Unit-V	802.X AND TCP/IP PROTOCOLS	14 Hours
	Revision and Examinations	10 Hours
Total		80 Hours

RATIONALE

Maintaining and servicing the computers, laptops and peripherals are essential requirements of the computer students. The clear understanding of computer network devices and protocols are also taught in this subject.

OBJECTIVES:

On completion of the following units of syllabus contents, the students can

- Identify the major components that make up the system unit.
- Understand the principle of operations of Keyboard, mouse and Displays.
- Study about the specification of I/O Ports of all I/O devices like serial, parallel, USB – Game port, Blue tooth and IP Connectors
- Understand the technology of high quality multiple color graphic output devices like Dot matrix, Inkjet, Laser, Line, MFP and computer system.
- Understand the operations to Power Supply devices.
- Know the use of diagnostic Software.
- Identify the major components of Laptop.
- Troubles shoot the problems in Laptop.
- Understand the concept of data communication.
- Discuss the advantages and disadvantages of different network topologies.
- Compare different network classifications based on different category.
- Know the use of different network devices.
- Understand the different layers of OSI and their functions.
- Compare different LAN protocols.
- Identify the protocols used in TCP/IP and compare with OSI model.
- Use of IP addressing and TCP/ IP protocols briefly.

DETAILED SYLLABUS

Content : Theory

Unit No.	Name of the Topic	Hours
I	<p>MOTHERBOARD COMPONENTS AND MEMORY STORAGE DEVICES</p> <p>1.1 Introduction: Parts - Mother board, expansion slots, memory, power supply, drives and front panel and rear panel connectors – Hardware, Software and Firmware.</p> <p>1.2 Processors: Architecture and block diagram of multicore Processor, Features of new processor(Definition only)-chipsets (Concepts only)</p> <p>1.3 Bus Standards Overview and features of PCI, AGP, USB, PCMCIA, Processor BUS - High Speed Bus</p> <p>1.4 Primary Memory: Introduction-Main Memory, Cache memory – DDR2- DDR3, RAM versions – 1TB RAM – DirectRDRAM</p> <p>1.5 Secondary Storage: Hard Disk – Construction – Working Principle – Specification of IDE, Ultra ATA, Serial ATA; HDD Partition - Formatting. Troubleshooting hard disk drives.</p> <p>1.6 Removable Storage: CD&DVD construction – reading & writing operations; CD-R,CD-RW; DVD-ROM, DVD-RW; construction and working of DVD Reader / Writer. Blue-ray: Introduction – Disc Parameters – Recording and Playback Principles – Solid state memory devices.</p>	<p>2 Hrs</p> <p>2 Hrs</p> <p>2 Hrs</p> <p>2 Hrs</p> <p>3 Hrs</p> <p>3 Hrs</p>
II	<p style="text-align: center;">I/O DEVICES AND INTERFACE</p> <p>2.1 Keyboard and Mouse: Keyboard: Signals – operation of membrane and mechanical keyboards–troubleshooting; wireless Keyboard. Mouse- types, connectors, operation of Optical mouse and Troubleshooting.</p> <p>2.2 Printers: Introduction – Types of printers– Dot Matrix, Inkjet, Laser, line printer, MFP (Multi Function Printer), Thermal printer - Operation – Construction – Features and Troubleshooting</p>	<p>2 Hrs</p> <p>4 Hrs</p>

	<p>2.3 I/O Ports: Serial, Parallel, USB, Game Port, Bluetooth interface, IR connector, fire ware, Signal specification problems with interfaces. 2 Hrs</p> <p>2.4 Displays and Graphic Cards: Panel Displays– Principles of LED, LCD and TFT Displays. SVGA Port signals – common problems and solutions. 2 Hrs</p> <p>2.5 Modem: Working principles – Broadband modems only (USB) - common problems and solutions 1 Hr</p> <p>2.6 Power Supply: Servo Stabilizers, online and offline UPS - working principles; Surge suppressors and spike isolators. SMPS: Principles of Operation and Block Diagram of ATX Power Supply, connector specifications. 3 Hrs</p>	
III	<p align="center">MAINTENANCE AND TROUBLE SHOOTING OF DESKTOP AND LAPTOPS</p> <p>3.1 Bios-setup: Standard CMOS setup, Advanced BIOS setup, Power management, advanced chipset features, PC Bios communication – upgrading BIOS, Flash BIOS -setup. 3 Hrs</p> <p>3.2 POST: Definition – IPL hardware – POST Test sequence – beep codes and error messages. 2 Hrs</p> <p>3.3 Diagnostic Software and Viruses: Computer Viruses – Precautions – Anti-virus Software – identify the signature of viruses – Firewalls and latest diagnostic software's. 2 Hrs</p> <p>3.4 Laptop: Difference between laptop and desktop- Types of laptop – block diagram – working principles–configuring laptops and power settings - SMD components, ESD and precautions. 2 Hrs</p> <p>3.5 Laptop components: Adapter – types, Battery – types and basic problems, RAM– types, CPU – types, Laptop Mother Board - block diagram, Laptop Keyboard –Mouse and Touchpad - Ports. 2 Hrs</p> <p>3.6 Installation and Troubleshooting: Formatting, Partitioning and Installation of OS – Trouble Shooting Laptop Hardware problems - Preventive maintenance techniques for laptops. 3 Hrs</p>	
IV	<p align="center">COMPUTER NETWORK DEVICES AND OSI LAYERS</p> <p>4.1 Data Communication: Components of a data communication – Data flow: simplex – half duplex – full duplex; Networks – Definition - Network criteria – Types of Connections: Point to point – multipoint; Topologies: Star, Bus, Ring, Mesh, Hybrid – Advantages and Disadvantages of each topology. 4 Hrs</p>	

	<p>4.2 Types of Networks : LAN – MAN – WAN – CAN – HAN – Internet – Intranet – Extranet , Client-Server, Peer To Peer Networks.</p> <p>4.3 Transmission Media : Classification of transmission media - Guided – Twisted pair, Coaxial, Fiber optics; Unguided – Radio waves – Infrared – LOS – VSAT – cabling and standards</p> <p>4.4 Network devices : Features and concepts of Switches – Routers(Wired and Wireless) – Gateways.</p> <p>4.5 Network Models : Protocol definition - standards - OSI Model – layered architecture – functions of all layers.</p>	<p>3 Hrs</p> <p>3 Hrs</p> <p>2 Hrs</p> <p>2 Hrs</p>
V	<p align="center">802.X AND TCP/IP PROTOCOLS</p> <p>5.1 Overview of TCP / IP : OSI & TCP/IP – Transport Layers Protocol – connection oriented and connectionless Services – Sockets – TCP & UDP.</p> <p>5.2 802.X Protocols : Concepts and PDU format of CSMA/CD (802.3) – Token bus (802.4) – Token ring (802.5) – Ethernet – type of Ethernet (Fast Ethernet, gigabit Ethernet) – Comparison between 802.3, 802.4 and 802.5</p> <p>5.3 Network Layers Protocol: IP – Interior Gateway Protocols (IGMP, ICMP, ARP, RARP Concept only).</p> <p>5.4 IP Addressing : Dotted Decimal Notation – Subnetting & Supernetting – VLSM Technique-IPv6 (concepts only)</p> <p>5.5 Application Layer Protocols: FTP– Telnet – SMTP– HTTP – DNS – POP</p>	<p>2 Hrs</p> <p>3 Hrs</p> <p>4 Hrs</p> <p>2 Hrs</p> <p>3 Hrs</p>

TEXT BOOKS:

1. IBM PC and CLONES, B.Govindrajalu, Tata McGrawhill Publishers, IBM PC and CLONES
2. Computer Installation and Servicing, D.Balasubramanian, Tata McGraw Hill
3. Computer Installation and Servicing
4. The complete PC upgrade and Maintenance, Mark Minasi, BPB Publication, The complete PC upgrade and Maintenance
5. Troubleshooting, Maintaining and Repairing PCs, Stephen J Bigelow ,Tata MCGraw Hill Publication ,Troubleshooting Maintaining and Repairing PCs
6. Upgrading and repairing laptops, Scott Mueller, QUE Publication, Upgrading and repairing laptops
7. Data Communication and networking, Behrouz A.Forouzan, Tata Mc-Graw Hill, New Delhi,
8. Data and Computer Communications, William Stallings, Prentice-Hall of India, Eighth Edition
9. Computer Networks, Andrew S.Tanenbaum, Prentice-Hall of India, New Delhi,

REFERENCE BOOKS:

1. Computer Networks,Achyut Godbole,Tata Mc-Graw Hill -New Delhi
2. Principles of Wireless Networks– A unified Approach, Kaveh Pahlavan and Prashant Krishnamurty, Pearson Education, 2002

DRAFT SYLLABUS

COMPUTER HARDWARE AND NETWORKS
MODEL QUESTION PAPER – 1

Time: 3 Hrs

Max. Marks: 75

PART – A

Marks 15 x 1 = 15

Note : Answer any 15 Questions. – All Questions carry equal marks

1. What is a Chipset?
2. Define: Direct RDRAM.
3. What is the Secondary Storage?
4. Give any two features of PCI.
5. Expand the term LED.
6. What are membrane and mechanical keyboard?
7. Define: Blue tooth interface.
8. List out the types of printers.
9. Define: BIOS.
10. List out the types of adapter.
11. Give the types of RAM.
12. Define: Power Management.
13. What is the data communication?
14. Define: Data Flow.
15. Expand the term: MAN.
16. What are the types of transmission media?
17. Give an example for connection-oriented protocol.
18. Expand the term: POP.
19. What is subnetting?
20. Define socket.

PART – B

Marks 5 x 12 = 60

Note : Answer all Questions.

21. A.1. Explain in detail about the architecture of Multi core Processor with neat diagram.

(OR)

- B.1. Explain the Processor Bus.
2. Explain the working principles of CD-R.

22. A.1. Write the signal specification problems with interfaces.
2. Explain the operation of optical mouse.

(OR)

B. Explain the working principle of modem.

23. A.1. Write about SMD Components.

2. What are the signatures of viruses?

(OR)

B. What is POST? List out the tests performed by POST

24. A. Explain in detail about OSI model with neat diagram.

(OR)

B. Explain in detail about Network devices.

25. A. Explain in detail about TCP and UDP.

(OR)

B. Discuss about 802.X protocols with neat diagram.

COMPUTER HARDWARE AND NETWORKS
MODEL QUESTION PAPER – 2

Time: 3 Hrs

Max. Marks: 75

PART – A

Marks 15 x 1 = 15

Note : Answer any 15 Questions. – All Questions carry equal marks

1. What is the other name of motherboard?
2. Define: BUS.
3. Define: processor.
4. What is the use of ultra ATA?
5. What is parallel port?
6. Define: Spike Isolator.
7. Expand the term UPS.
8. What is Multi Function Printer?
9. What is CMOS?
10. What are the types of error messages?
11. Give an example for anti-virus software.
12. What is ESD?
13. Give any two advantages of star topology.
14. What is an adaptive routing?
15. What is half duplex?
16. What is VSAT?
17. What is connectionless protocol?
18. Expand: IGMP.
19. What is supernetting?
20. What is DNS?

PART – B

Marks 5 x 12 = 60

Note : Answer all Questions.

21. A.1. How will you format the hard disk?
2. Draw and explain the USB.

(OR)

B. Discuss the format and version of DVD-ROM.

22. A.1. Explain in detail about SVGA.
2. Write the working principle of LCD.

(OR)

B. Explain the working of wireless keyboard with block diagram.

23. A. How will you upgrade BIOS?

(OR)

B.1. Draw the block diagram of laptop motherboard and explain it.

2. Write down the steps involved in OS installation.

24. A. With neat diagram explain the types of networks.

(OR)

B. Discuss about unguided transmission media with neat diagram.

25. A.1. With neat diagram explain about TELNET.

2. Explain in detail about SMTP.

(OR)

B.1. With neat diagram explain about VLSM technique.

2. Write short notes on IPV6.

DRAFT SYLLABUS

STATE BOARD OF TECHNICAL EDUCATION AND TRAINING, TAMIL NADU
SYLLABUS FOR DIPLOMA IN ELECTRICAL AND ELECTRONICS ENGINEERING
L-SCHEME

Course Name : Diploma in Electrical and Electronics Engineering
 Subject Code : **23064**
 Semester : VI Semester
 Subject Title : **WIRING & WINDING PRACTICAL**

TEACHING AND SCHEME OF EXAMINATION

No. of weeks per Semester : 16

Subject	Instruction		Examination		
	Hours / Week	Hours / Semester	Assessment marks		
			Internal	Board Examination	Total
Wiring and Winding Practical	6	96	25	75	100

RATIONALE

To provide hands on experience in Electrical wiring and winding it becomes necessary to include this subject.

OBJECTIVES

At the end of this practical subject the students should be able to

- Execute the wiring to control three lamps Individually
- Execute the stair case wiring for G+n floors
- Execute the emergency alarm circuit
- Execute the wiring to connect a single phase motor with main switch , D.O.L starter and M.C.B
- Execute the wiring to connect a 3 phase Induction motor with main switch, star/delta starter and E.L.C.B.
- Execute the wiring for 1 phase service connection with necessary items.
- Execute the wiring to control lamps (Sodium vapour lamp, mercury vapour lamp, Fluorescent Tube and Neon sign lamp) with a provision of fuse/ M.C.B/Electronic chock / switches
- Execute the wiring for test board with necessary items.
- Know the consequences of disconnection of Neutral in 3 phase 4 wire system.
- Execute the Tunnel wiring
- Prepare winding for potential Transformer and No volt coil with the knowledge of Design.
- Give end connections for 3 phase Induction motor winding.

23064 WIRING & WINDING PRACTICAL

Contents : Practical

List of Experiments

WIRING

1. Control three lamps individually providing MCB to protect the circuit.
2. Execute the stair case wiring for G+3 floors.
3. Execute the Emergency alarm circuit with a provision of 3 bells in series to ring together when any one of the 3 push button is pressed .
4. Execute the wiring using single phase main switch, Single phase D.O.L starter and miniature C.B to install single phase Induction motor.
5. Execute the wiring using Three phase main switch, Star/delta starter and Earth Leakage C.B to install 3phase Induction motor with a provision for arrangement to trip ELCB when fault occurs.
6. Execute the wiring for service connection with single phase Energy meter cutout, main switch, 4way D.B, Indicator lamp and connect a load on any one sub circuit.
7. Execute the wiring for connecting sodium vapour and mercury vapour Lamp with single phase supply.
8. Execute the Fluorescent Tube light connection with Electronic choke and test it. Also measure the voltage across the tube light fitting.
9. Construct a simple model (with minimum 3 Blocks)to know the usage of Neon tube circuit in advertisement .
10. Prepare a test board with necessary supply provision, Indicator lamp, fuse unit to test electrical appliances.
11. In a 3 phase, 4 wire system, connect two lamps in different ratings between R-Phase to Neutral and y-phase to Neutral respectively. Disconnect the Neutral using SPST switch. Note the changes occur in two lamps.
12. Execute the Tunnel wiring at least for four lamps fixed at equal intervals successively.

WINDING

13. Design and wind 230/12-0-12 volt, 500mA Transformer and test it.
14. Design and wind a Novolt coil used in starter.
15. Wind and insert the coils for ceiling fan motor (minimum 2 coils)
16. Give end connection for a 3 phase Induction motor winding for a 2 pole/ 4 pole operations and runit. Measure the No load current and speed..

Equipment / Materials required

Sl.No.	Description	Specification	Qty
1	SPST Flush type switch	250 V, 5A	15 Nos.
2.	Batten Lamp holder		10 Nos.
3.	Round block		20 Nos.
4.	Switch board	20 cm x 15 cm	1 No.
		10 cm x 10 cm	15 Nos.
5.	M.C.B.	250 V, 10 A, 2 pole	2 Nos.
6.	Push button switch	250 V, 5A	5 Nos.
7.	2 plate ceiling rose	250 V, 5A	10 Nos.
8.	Electric bell	250 V, 5A	3 Nos.
9.	Single phase D.P.I.C. Main switch	250 V, 16A	3 Nos.
10.	Single phase D.O.L. Starter	250 V, 10 A	1 No.
11.	Three phase T.P.I.C. Main switch	500 V, 30 A	2 Nos.
12.	Star / delta starter	440 V, 5 H.P.	1 No.
13.	E.L.C.B.	500 V, 30 A	1 No.
14.	Single phase, 2 wire watt-hour meter	250 V, 15A, 50 hz	1 No.
15.	Cut out	16 A	1 No.
16.	Single phase, 4 way distribution Box	250 V, 15 A	1 No.
17.	Mercury vapour lamp with accessories		1 set
18.	Sodium vapour lamp with accessories		1 set
19.	Fluorescent tube light with electronic choke and holder	40 W	1 set
20.	Neon tube lamp (any sign)		3 blocks
21.	Two way flush type switch	250 V, 5A	10 Nos.
22.	Wooden box	30 cm x 15 cm	1 No.
23.	PVC pipe	1"	Required qty
24.	Saddle clips	1"	Required qty
25.	Copper wire	2.5 sq.mm. 1.5 sq.mm	Required qty
26.	1" junction box	One way Two way Three way	Required qty
27.	Screws		Required qty

28.	Bare copper wire	2.5 sq. mm	Required qty
29.	Lamps (C.F.L. or Incandescent)	Different ratings	Required qty
30.	Transformer core:		
	EI60 type stampings of 0.35 mm thickness		55 Nos.
31.	Readymade bobbins (EI60/21)		Required qty
32.	Winding coil (copper)	25 SWG 36 SWG 37 SWG 38 SWG	Required qty
33.	Varnish		Required qty
34.	Winding machine		1 No.
35.	Ceiling fan (motor)		1 No.
36.	Single phase induction motor	0.5 H.P. 50 Hz, 240 V	1 No.
37.	Three phase squirrel cage induction motor	3 H.P., 500 V, 50 Hz	2 Nos.

Allocation of marks

- | | | |
|---------------------------|---|----------|
| 1. Wiring diagram /Design | - | 20 marks |
| 2. Execution | - | 40 marks |
| 3. Result | - | 10 marks |
| 4. Viva-voce | - | 05 marks |

Total marks	-	75 marks
-------------	---	----------

**STATE BOARD OF TECHNICAL EDUCATION AND TRAINING, TAMIL NADU
SYLLABUS FOR DIPLOMA IN ELECTRICAL AND ELECTRONICS ENGINEERING
L-SCHEME**

Course Name : Diploma in Electrical and Electronics Engineering
Subject Code : **23065**
Semester : VI Semester
Subject Title : **COMPUTER AIDED ELECTRICAL DRAWING PRACTICAL**

TEACHING AND SCHEME OF EXAMINATION

No. of weeks per Semester : 16

Subject	Instruction		Examination		
	Hours / Week	Hours / Semester	Assessment marks		
			Internal	Board Examination	Total
COMPUTER AIDED ELECTRICAL DRAWING PRACTICAL	5	80	25	75	100

RATIONALE

Drawing boards and drawing papers are not at all used for engineering drawing. All the drawings are made on computers using appropriate software. There are many advantages of computer aided drawing over traditional drawing. This subject is introduced in order to impart skill of making computer aided electrical drawing.

OBJECTIVES

At the end of the semester the student must be able to draw

- 2D diagrams using Auto CAD
- Symbols widely used in Electrical and Electronics circuits
- Starter circuits and winding diagrams
- The line diagrams of substations
- The simple basic diagrams for laboratory circuits

23065 COMPUTER AIDED ELECTRICAL DRAWING PRACTICAL

Contents : Practical

List of Experiments

DRAWING - ELECTRICAL SYMBOLS

01. Draw the symbols for machines : Armatures, Alternators, Field winding
- Shunt, Series and Compound, Transformers, Auto Transformers
02. Draw the symbols for components : Resistor, Capacitor, Inductor,
Diode, Transistor, FET, SCR, UJT, TRIAC, DIAC, Gates AND, OR,
NOT, NAND, NOR, EXOR
03. Draw the symbols used in circuits : Relays, contactors, fuses, main
switch, electric bell, earth, antenna, DPST, DPDT, TPST, Neutral link
04. Draw the symbols for instruments : Ammeter, Voltmeter, Wattmeter,
Energy meter, Frequency meter, Power factor meter, Timers, Buzzers

DRAWING - ELECTRICAL CONNECTION DIAGRAMS

01. Draw the panel wiring diagram of two shunt generators in parallel.
02. Draw the panel wiring diagram of two single phase alternators in parallel.
03. Draw the winding diagram of lap connected DC armature with commutator connections and
brush positions.
04. Draw the winding diagram of wave connected DC armature with commutator connection
and brush positions.
05. Draw the mesh winding diagram of a three phase induction motor.
06. Draw the concentric winding diagram of a single phase induction motor.
07. Draw the control circuit of jogging.
08. Draw the control circuit of automatic rotor starters.
09. Draw the connection diagram of ON load tap changer.
10. Draw the circuit of three phase transformers in parallel.
11. Draw the connections of three point starter.
12. Draw the connections of automatic star - delta starter.
13. Draw the connections of direct on line starter.
14. Draw the single line diagram of 110 KV / 11 KV receiving substation

NOTE FOR EXAMINERS

1. Five symbols should be asked from exercise 1 to 4 with at least one from each
2. One sketch should be asked from exercise 5 to 18.
3. Printed output of the given symbols and sketch is to be evaluated

MODEL QUESTION

- I Draw the symbol of Inductor, Power factor meter, DIAC, Buzzer, Alternator 10 marks
- II Develop the Drawing for the connection of ON load tap changer in AutoCAD.
Take the Printed output. 60 marks
- III Viva – Voce 05 marks

DRAFT SYLLABUS

**STATE BOARD OF TECHNICAL EDUCATION AND TRAINING, TAMIL NADU
SYLLABUS FOR DIPLOMA IN ELECTRICAL AND ELECTRONICS ENGINEERING
L-SCHEME**

Course Name : Diploma in Electrical and Electronics Engineering
 Subject Code : **23084**
 Semester : VI Semester
 Subject Title : **POWER ELECTRONICS PRACTICAL**

TEACHING AND SCHEME OF EXAMINATION

No. of weeks per Semester : 16

Subject	Instruction		Examination		
	Hours / Week	Hours / Semester	Assessment marks		
			Internal	Board Examination	Total
POWER ELECTRONICS PRACTICAL	5	80	25	75	100

RATIONALE

AC to DC conversion, DC to AC inversion, Voltage and Current controls, Voltage to Frequency conversion with high voltage supplies became possible with the introduction of Power Electronic Devices. Without these operations the electric drives are useless in these days. This subject is introduced to impart practical skills to the students in using some important power electronic devices and circuits.

OBJECTIVES

On completion of the following experiments, the students must be able to

- To draw the characteristics of SCR
- Get the knowledge about the trigger circuit
- Draw the input/output waveform using semi converter controlled bridge and FCB
- Know the performance of lamp control using DIAC-TRIAC
- Learn the various techniques used for turn-off of Thyristor
- Learn the half wave controlled rectifier with R- Load
- Draw the waveform of parallel inverter
- Draw the output waveform of DC chopper
- Learn the concept of single phase to single phase cyclo converter
- Measure the output voltage of step up chopper.
- Find the performance of speed control of universal motor
- Understand the concept of closed loop control of AC motor (microprocessor controlled PWM)
- Know the performance of speed control of DC motor by varying firing angle
- Understand the concept of closed loop control of DC motor using microprocessor
- Draw the output waveform of DC chopper using MOSFET/IGBT

23084 POWER ELECTRONICS PRACTICAL

List of Experiments

1. Characteristics of SCR and marking important parameters.
2. Line synchronized Ramp trigger circuit using UJT with AC load.
3. Lamp control circuit using DIAC – TRIAC.
4. SCR commutation circuits (Class B & Class D)
5. Single phase semi controlled bridge with R- Load
6. Single phase fully controlled bridge with RL- Load
7. Half wave controlled rectifier with R- Load.
8. DC chopper control circuit using thyristor (any one).
9. Construct and test the step up chopper.
10. PWM based step down DC chopper using MOSFET/IGBT.
11. Single phase Single pulse / Sinusoidal PWM inverter using MOSFET/IGBT.
12. SMPS using MOSFET/IGBT.
13. DC shunt motor speed control circuit.
14. Closed loop speed control of DC motor using microprocessor.
15. Universal motor control circuit using TRIAC.
16. Open loop speed control of Single phase AC motor.
17. Single phase parallel inverter using MOSFET/IGBT
18. Single phase to single phase cyclo converter.
19. Micro computer based pulse width modulation control of induction motor.

Scheme of Evaluation

Sl No.	Activity of the Candidate	Maximum Marks to be awarded
1	Drawing Correct Diagram and writing Details of the Components/Equipments/Machines used	15
2	Making the correct circuit connections	15
3	Conducting the Experiment <ul style="list-style-type: none">- Following the correct procedure- Taking the appropriate readings- Following the appropriate safety procedure	25
4	Tabulation of Readings Interpretation of Results Graphical Representation (if required)	15
5	Viva-voce (Questions related to the given experiments only)	5
	Total Marks (External)	75

**STATE BOARD OF TECHNICAL EDUCATION AND TRAINING, TAMIL NADU
SYLLABUS FOR DIPLOMA IN ELECTRICAL AND ELECTRONICS ENGINEERING
L-SCHEME**

Course Name : Diploma in Electrical and Electronics Engineering
 Subject Code : **23085**
 Semester : VI Semester
 Subject Title : **BIO MEDICAL INSTRUMENTATION PRACTICAL**

TEACHING AND SCHEME OF EXAMINATION

No. of weeks per Semester : 16

Name of Subject	Instruction		Examination		
	Hours / Week	Hours / Semester	Assessment marks		
			Internal	Board Exam	Total
BIO MEDICAL INSTRUMENTATION PRACTICAL	5	80	25	75	100

RATIONALE

Recent advances in medical field have been fuelled by the instruments developed by the Electronics and Instrumentation Engineers. Pacemakers, Ultrasound Machine CAT, Medical diagnostic systems are few names which have been contributed by engineers. Now health care industry uses many instruments which are to be looked after by instrumentation engineers. This subject will enable the students to learn the basic principles of different instruments/equipment used in the health care industry. The practical work done in this area will impart skill in the use, servicing and maintenance of these instruments/equipment. Proficiency in this area will widen the knowledge and skill of diploma holders in the field of biomedical instrumentation.

ELECTIVE PRACTICAL - II

23085 BIO – MEDICAL INSTRUMENTATION PRACTICAL

List of Experiments

1. Operation and function of all the controls of hospital X-Ray machine (visit at hospital)
2. Operation and function of all the controls of dental X-Ray machine (Visit to Hospital)
3. Identification of different block/sub system of circuits in X-Ray machine
4. Measurement of skin contact impedance and technique to reduce it.
5. Observe its wave shape on CRO the output of blood pressure transducers body temperature transducers and pulse sensors
6. Use of sphygmomanometer for measurement of blood pressure
7. Concept of ECG system and placement of electrodes
8. Measurement of leakage currents with the help of safety tester
9. PH measurement of given biological sample
10. Concept of EMG system and placement of electrode
11. Measurement of respiration rate using thermistor
12. Concept of EEG system and placement of electrode
13. Identification of different types of PH electrodes

STATE BOARD OF TECHNICAL EDUCATION & TRAINING, TAMILNADU L – SCHEME

(Implemented from the academic year 2012 - 2013 onwards)

Course Name : Diploma in Electrical and Electronics Engineering.
Subject Code : 24684
Semester : VI Semester
Subject Title : **COMPUTER SERVICING AND NETWORK PRACTICAL**

SCHEME OF INSTRUCTION AND EXAMINATION

No. of weeks per semester: 16 weeks

Subject	Instructions		Examination		
	Hours / Week	Hours / Semester	Internal Assessment	Board Examination	Total
COMPUTER SERVICING AND NETWORK PRACTICAL	4	64	25	75	100

RATIONALE

The course aims at making the students familiar with various parts of computers and laptops and how to assemble them and the different types of peripherals desired. In addition, the course will provide the students with necessary knowledge and skills in computer and laptop software installation and maintenance and to make him diagnose the software faults. This subject also gives the knowledge and competency to diagnose the problems in computer hardware and peripherals and also gives the knowledge for trouble shooting for systematic repair and maintenance of computers and laptops

OBJECTIVES

On completion of the following exercises, the students must be able to

- Know the various indicators, switches and connectors used in Computers.
- Familiarize the layout of SMPS, motherboard and various Disk Drives.
- Configure Bios set up options.
- Install various secondary storage devices with memory partition and formatting.
- Know the various types of printer installation and to handle the troubleshooting ability.
- Acquire the practical knowledge about the installation of various devices like scanner, web camera, cell phone and bio-metric devices.
- Assemble PC system and checking the working condition.
- Installation of Dual OS in a system.
- Identify the problems in Computer systems, software installation and rectification also.
- Assembling and disassembling of Laptop to identify the parts and to install OS and configure it.
- Enable to perform different cabling in a network.
- Configure Internet connection and use utilities to debug the network issues.
- Configure router for any topology

LAB EXERCISES

PART A – COMPUTER SERVICING PRACTICALS	
1	<p>Identification of System Layout.</p> <ul style="list-style-type: none"> a) Front panel indicators & switches and Front side & rear side connectors. b) Familiarize the computer system Layout: Marking positions of SMPS, Motherboard, FDD, HDD, CD, DVD and add on cards. c) Configure bios setup program and troubleshoot the typical problems using BIOS utility.
2	<p>HARD DISK</p> <ul style="list-style-type: none"> a) Install Hard Disk. b) Configure CMOS-Setup. c) Partition and Format Hard Disk. d) Identify Master /Slave / IDE Devices. e) Practice with scan disk, disk cleanup, disk De-fragmenter, Virus Detecting and Rectifying Software.
3	<ul style="list-style-type: none"> a) Install and Configure a DVD Writer and a Blu-ray Disc writer. b) Recording a Blank DVD and Blu-ray Disc.
4	<p>Printer Installation and Servicing:</p> <ul style="list-style-type: none"> a) Head Cleaning in dot matrix printer b) Install and configure Dot matrix printer and Laser printer c) Troubleshoot the above printers. d) Check and connect the data cable connectivity
5	<p>Install and configure Scanner, Web cam, Cell phone and bio-metric device with system. Troubleshoot the problems</p>
6	<p>Assemble a system with add on cards and check the working condition of the system and install OS.</p>
7	<p>Dual OS Installation</p>
8	<p>Assembling and Disassembling of Laptop to identify the parts and to install OS and configure it.</p>

PART B – COMPUTER NETWORK PRACTICALS

9	Do the following Cabling works in a network a) Cable Crimping b) Standard Cabling c) Cross Cabling d) IO connector crimping e) Testing the crimped cable using a cable tester
10	Configure Host IP, Subnet Mask and Default Gateway in a system in LAN (TCP/IP Configuration). Configure Internet connection and use IPCONFIG, PING / Tracert and Netstat utilities to debug the network issues
11	Interface two PCs using Peer To Peer network using connectivity devices – Switch and Router in a LAN and share the Drives and Folders.
12	Transfer files between systems in LAN using FTP Configuration, install Print server in a LAN and share the printer in a network.
13	Configure DNS to establish interconnection between systems and describe how a name is mapped to IP Address
14	Install and configure Network Devices: HUB, Switch and Routers
15	Install and Configure Wired and Wireless NIC and transfer files between systems in LAN and Wireless LAN.

PART C (NOT FOR EXAMINATION)

	<p>Visit Any industry/ Institute (Engineering colleges, University campus etc.,) and study the following:</p> <ul style="list-style-type: none">• Type and configuration of client PCs and OS• Type and configuration of Server and Domains Used• Type of Networking (Topology and medium used)• Different Network devices used (Switches, Routers, Access points etc.,)• Different types of peripherals used• Applications used by the user. <p>Prepare a detailed report of about 4 to 5 pages and include in the lab record.</p>
--	--

SCHEME OF VALUATION

Procedure Writing – One Question from PART - A	10 Marks
Procedure Writing – One Question from PART - A	15 Marks
Executing program (PART – A)	15 Marks
Executing program (PART – B)	20 Marks
Result with printout (PART – A)	5 Marks
Result with printout (PART – B)	5 Marks
VIVA - VOCE	5 Marks
TOTAL	75 Marks

COMPUTER SERVICING AND NETWORK PRACTICAL - REQUIREMENTS

PART A – COMPUTER SERVICING PRACTICAL	
1.	<p><u>Hardware Requirements :</u></p> <ul style="list-style-type: none"> • Computer with Pentium / Core processors with add on cards – 36Nos • Hard disk drive - 06 Nos • CD Drive - 06 Nos • DVD Writer - 06 Nos • Blank DVD - 50 Nos • Blank Blu-ray disk - 50 Nos • Head cleaning CD • Dot matrix Printer - 06 Nos • Laser Printer - 06 Nos • Digital Camera - 02 Nos • Web Camera - 02 Nos • Scanner - 02 Nos • Blue tooth device and cell phone - 02 Nos • Bio-metric device - 02 Nos • Laptop - 18Nos <p><u>Software Requirements:</u></p>
2.	<ul style="list-style-type: none"> • Windows XP operating system • Linux operating system • Disk Manager (for the purpose of partition and format) • Norton or E-Trust Antivirus software • Scandisk • DVD Writer S/W • CD Burning S/W (Ahead Nero or latest S/W) • Blu-ray Burning S/W

PART B – COMPUTER NETWORK PRACTICAL

1.	<u>Tools Requirement</u> <ul style="list-style-type: none">• Crimping Tool• Network Cables	- 06 Nos
	<u>Equipment Requirement</u> <ul style="list-style-type: none">• Modem• Laser Printer	- 01 No - 01 No
2.	<ul style="list-style-type: none">• Hub• Router• Switch	- 01 No - 01 No - 01 No
	<u>System Requirement</u> <ul style="list-style-type: none">• Pentium Systems with on board Ethernet Card (NIC)	- 18 Nos
3.	<u>Software Requirement</u> <ul style="list-style-type: none">• Windows 2000 or 2003 or LINUX Server.• OS Windows XP with service pack• Drivers Software	
4.		

DRAFT SYLLABUS

. L – SCHEME
(Implemented from the academic year 2012 - 2013 onwards)

Course Name : Diploma in Information Technology.
 Subject Code : 23067
 Semester : VI Semester
 Subject Title : **PROJECT WORK**

TEACHING AND SCHEME OF EXAMINATIONS:

No. of Weeks per Semester : 16 Weeks

Subject	Instruction		Examination		
	Hours/ Week	Hours/ Semester	Assessment Marks		
			Internal	Board Exam	Total
PROJECT WORK	3	48	25	75	100

Minimum Marks for Pass is 50 out of which minimum 35 marks should be obtained out of 75 marks in the board Examination alone.

OBJECTIVES:

- Implement the theoretical and practical knowledge gained through the curriculum into an application suitable for a real practical working environment preferably in an industrial environment
- Get exposure on industrial environment and its work ethics.
- Understand what entrepreneurship is and how to become an entrepreneur.
- Learn and understand the gap between the technological knowledge acquired through curriculum and the actual industrial need and to compensate it by acquiring additional knowledge as required.
- Carry out cooperative learning through synchronous guided discussions within the class in key dates, asynchronous document sharing and discussions, as well as to prepare collaborative edition of the final project report.
- Understand the facts and importance of environmental management.

Understand and gain knowledge about disaster management

INTERNAL ASSESSMENT:

The internal assessment should be calculated based on the review of the progress of the work done by the student periodically as follows.

Detail of assessment	Period of assessment	Max. Marks
First Review	6 th week	10
Second Review	14 th week	10
Attendance	Entire semester	5
Total		25

EVALUATION FOR BOARD EXAMINATION:

Details of Mark allocation	Max Marks
Marks for Report Preparation, Demo, Viva-voce	45
Marks for answers of 15 questions which is to be set by the external examiner from the given question bank consisting of questions in the following three topics Entrepreneurship, Disaster Management and Environmental Management. Out of fifteen questions five questions to appear from each of the above topics i.e. 5 questions x 3 topics = 15 questions 15 questions x 2marks = 30 Marks	30
Total	75

DETAILED SYLLABUS

ENTREPRENEURSHIP, ENVIRONMENTAL & DISASTER MANAGEMENT

1. ENTREPRENEURSHIP

- 1.1 Introduction – Entrepreneur - characteristics of Entrepreneur - contributions of an Entrepreneur - functions of entrepreneur - Barriers to entrepreneurship - Roll of government in Entrepreneurial development.
- 1.2 Small scale industries (SSI) - SSI role in country's economic growth – importance of SSI - starting of an SSI - Government organization and Non-governmental organizations supporting SSI - DIC, NSIC, SIDO, KVIC, Development banks and their objectives - role of commercial banks in assisting SSI - Women entrepreneurs and opportunities – Subsidy and concessions to Small Scale Industries.

2. ENVIRONMENTAL MANAGEMENT

- 2.1 Introduction – Environmental Ethics – Assessment of Socio Economic Impact – Environmental Audit – Mitigation of adverse impact on Environment – Importance of Pollution Control – Types of Industries and Industrial Pollution.
- 2.2 Solid waste management – Characteristics of Industrial wastes – Methods of Collection, transfer and disposal of solid wastes – Converting waste to energy – Hazardous waste management Treatment technologies.
- 2.3 Waste water management – Characteristics of Industrial effluents – Treatment and disposal methods – Pollution of water sources and effects on human health.
- 2.4 Air pollution management – Sources and effects – Dispersion of air pollutants – Air pollution control methods – Air quality management.
- 2.5 Noise pollution management – Effects of noise on people – Noise control methods.

3. DISASTER MANAGEMENT

- 3.1 Introduction – Disasters due to natural calamities such as Earthquake, Rain, Flood, Hurricane, Cyclones etc – Man made Disasters – Crisis due to fires, accidents, strikes etc – Loss of property and life..
- 3.2 Disaster Mitigation measures – Causes for major disasters – Risk Identification – Hazard Zones – Selection of sites for Industries and residential buildings – Minimum distances from Sea – Orientation of Buildings – Stability of Structures – Fire escapes in buildings - Cyclone shelters – Warning systems.
- 3.3 Disaster Management – Preparedness, Response, Recovery – Arrangements to be made in the industries / factories and buildings – Mobilization of Emergency Services - Search and Rescue operations – First Aids – Transportation of affected people – Hospital facilities – Fire fighting arrangements – Communication systems – Restoration of Power supply – Getting assistance of neighbors / Other organizations in Recovery and Rebuilding works – Financial commitments – Compensations to be paid – Insurances – Rehabilitation.

LIST OF QUESTIONS

1. ENTREPRENEURSHIP

1. Define the term Entrepreneur.
2. What is Entrepreneurship? Explain.
3. List the various stages of decisions an entrepreneur has to make before reaching the goal of his project.
4. What is innovation?
5. State briefly the role of an entrepreneur in the economic growth of a country.
6. List the characteristics of an Entrepreneur.
7. What are the critical elements of an Entrepreneur?
8. State the major functions of an Entrepreneur.
9. What are barriers to Entrepreneurship?
10. Define Small Scale Industry.
11. What are the qualities of Entrepreneur?
12. What are the benefits of Entrepreneur?
13. What are the various SSI that can flourish in your district?
14. Identify the infrastructural needs for an industry.
15. What are the various agencies involved in the establishment and development of various SSI?
16. Name some of the agencies funding SSI.
17. Explain the roles played by Government in Entrepreneurial development.
18. What are the various concessions and incentives available for a SSI.
19. Name some consumer products with wide demand that can be manufactured by a SSI?
20. What is feasibility study?
21. What is the importance of SSI?
22. What is DIC? State its functions.

23. What is NSIC? State its functions.
24. What is SIDO? State its functions.
25. Name the Development Banks in India working towards Entrepreneurial development.
26. State the role of commercial bank in assisting SSI sector.
27. What are the different phases of Entrepreneurial Development programme?
28. What is an Industrial Estate?
29. What are the facilities available in an Industrial Estate?
30. Identify the various training agencies associated with SSI.
31. List the governmental agencies from whom you shall get financial assistance for a SSI.
32. What is KVIC? State its objectives.
33. Name some state finance corporations.
34. What are the steps involved in preparing a feasibility report?
35. What are the factors to be considered regarding raw materials for a SSI?
36. What are the features of a SSI?
37. What are the advantages of becoming an Entrepreneur?
38. Name the Organizations offering assistance for the development of Women entrepreneurs.
39. State the business opportunities for Women entrepreneurs.
40. State the different subsidies given to SSI's.

2. ENVIRONMENTAL MANAGEMENT

1. What is the responsibility of an Engineer-in-charge of an Industry with respect to Public Health?
2. Define Environmental Ethic.
3. How Industries play their role in polluting the environment?
4. What is the necessity of pollution control? What are all the different organizations you know, which deal with pollution control?
5. List out the different types of pollutions caused by a Chemical / Textile / Leather / Automobile / Cement factory.
6. What is meant by Hazardous waste?
7. Define Industrial waste management.
8. Differentiate between garbage, rubbish, refuse and trash based on their composition and source.
9. Explain briefly how the quantity of solid waste generated in an industry could be reduced.
10. What are the objectives of treatments of solid wastes before disposal?
11. What are the different methods of disposal of solid wastes?
12. Explain how the principle of recycling could be applied in the process of waste minimization.
13. Define the term 'Environmental Waste Audit'.
14. List and discuss the factors pertinent to the selection of landfill site.
15. Explain the purpose of daily cover in a sanitary landfill and state the minimum desirable depth of daily cover.

16. Describe any two methods of converting waste into energy.
17. What actions, a local body such as a municipality could take when the agency appointed for collecting and disposing the solid wastes fails to do the work continuously for number of days?
18. Write a note on Characteristics of hazardous waste.
19. What is the difference between municipal and industrial effluent ?
20. List few of the undesirable parameters / pollutants anticipated in the effluents from oil refinery industry / thermal power plants / textile industries / woolen mills / dye industries / electroplating industries / cement plants / leather industries (any two may be asked)
21. Explain briefly the process of Equalization and Neutralization of waste water of varying characteristics discharged from an Industry.
22. Explain briefly the Physical treatments "Sedimentation" and "Floatation" processes in the waste water treatment.
23. Explain briefly when and how chemical / biological treatments are given to the waste water.
24. List the four common advanced waste water treatment processes and the pollutants they remove.
25. Describe refractory organics and the method used to remove them from the effluent.
26. Explain biological nitrification and de-nitrification.
27. Describe the basic approaches to land treatment of Industrial Effluent.
28. Describe the locations for the ultimate disposal of sludge and the treatment steps needed prior to ultimate disposal.
29. List any five Industries, which act as the major sources for Hazardous Air Pollutants.
30. List out the names of any three hazardous air pollutants and their effects on human health.
31. Explain the influence of moisture, temperature and sunlight on the severity of air pollution effects on materials.
32. Differentiate between acute and chronic health effects from Air pollution.
33. Define the term Acid rain and explain how it occurs.
34. Discuss briefly the causes for global warming and its consequences
35. Suggest suitable Air pollution control devices for a few pollutants and sources.
36. Explain how evaporative emissions and exhaust emissions are commonly controlled.
37. What are the harmful elements present in the automobile smokes? How their presence could be controlled?
38. What is the Advantage of Ozone layer in the atmosphere? State few reasons for its destruction.
39. Explain the mechanism by which hearing damage occurs.
40. List any five effects of noise other than hearing damage.
41. Explain why impulsive noise is more dangerous than steady state noise.
42. Explain briefly the Source – Path – Receiver concept of Noise control.
43. Where silencers or mufflers are used ? Explain how they reduce the noise.
44. Describe two techniques to protect the receiver from hearing loss when design / redress for noise control fail.
45. What are the problems faced by the people residing along the side of a railway track and near to an Airport? What provisions could be made in their houses to reduce the problem?

3. DISASTER MANAGEMENT

1. What is meant by Disaster Management? What are the different stages of Disaster management?
2. Differentiate Natural Disasters and Man made Disasters with examples.
3. Describe the necessity of Risk identification and Assessment Surveys while planning a project.
4. What is Disasters recovery and what does it mean to an Industry?
5. What are the factors to be considered while planning the rebuilding works after a major disaster due to flood / cyclone / earthquake? (Any one may be asked)
6. List out the public emergency services available in the state, which could be approached for help during a natural disaster.
7. Specify the role played by an Engineer in the process of Disaster management.
8. What is the cause for Earthquakes? How they are measured? Which parts of India are more vulnerable for frequent earthquakes?
9. What was the cause for the Tsunami 2004 which inflicted heavy loss to life and property along the coast of Tamilnadu ? Specify its epicenter and magnitude.
10. Specify the Earthquake Hazard Zones in which the following towns of Tamilnadu lie: (a) Chennai (b) Nagapattinam (c) Coimbatore (d) Madurai (e) Salem.
11. Which parts of India are experiencing frequent natural calamities such as (a) heavy rain fall (b) huge losses due to floods (c) severe cyclones
12. Define basic wind speed. What will be the peak wind speed in (a) Very high damage risk zone – A, (b) High damage risk zone, (c) Low damage risk zone.
13. Specify the minimum distance from the Sea shore and minimum height above the mean sea level, desirable for the location of buildings.
14. Explain how the topography of the site plays a role in the disasters caused by floods and cyclones.
15. Explain how the shape and orientation of buildings could reduce the damages due to cyclones.
16. What is a cyclone shelter ? When and where it is provided ? What are its requirements ?
17. What Precautionary measures have to be taken by the authorities before opening a dam for discharging the excess water into a canal/river ?
18. What are the causes for fire accidents ? Specify the remedial measures to be taken in buildings to avoid fire accidents.
19. What is a fire escape in multistoried buildings ? What are its requirements ?
20. How the inmates of a multistory building are to be evacuated in the event of a fire/Chemical spill/Toxic Air Situation/ Terrorist attack, (any one may be asked).
21. Describe different fire fighting arrangements to be provided in an Industry.
22. Explain the necessity of disaster warning systems in Industries.
23. Explain how rescue operations have to be carried out in the case of collapse of buildings due to earthquake / blast / Cyclone / flood.
24. What are the necessary steps to be taken to avoid dangerous epidemics after a flood disaster?

25. What relief works that have to be carried out to save the lives of workers when the factory area is suddenly affected by a dangerous gas leak / sudden flooding ?
26. What are the difficulties faced by an Industry when there is a sudden power failure? How such a situation could be managed?
27. What are the difficulties faced by the Management when there is a group clash between the workers? How such a situation could be managed?
28. What will be the problems faced by the management of an Industry when a worker dies because of the failure of a mechanical device due to poor maintenance? How to manage such a situation ?
29. What precautionary measures have to be taken to avoid accidents to labourers in the Industry in a workshop / during handling of dangerous Chemicals / during construction of buildings / during the building maintenance works.
30. Explain the necessity of medical care facilities in an Industry / Project site.
31. Explain the necessity of proper training to the employees of Industries dealing with hazardous products, to act during disasters.
32. What type of disaster is expected in coal mines, cotton mills, Oil refineries, ship yards and gas plants?
33. What is meant by Emergency Plan Rehearsal? What are the advantages of such Rehearsals?
34. What action you will take when your employees could not reach the factory site because of continuous strike by Public Transport workers?
35. What immediate actions you will initiate when the quarters of your factory workers are suddenly flooded due to the breach in a nearby lake / dam, during heavy rain?
36. What steps you will take to avoid a break down when the workers union of your Industry have given a strike notice?
37. List out few possible crisis in an organization caused by its workers? What could be the part of the middle level officials in managing such crisis?
38. What types of warning systems are available to alert the people in the case of predicted disasters, such as floods, cyclone etc.
39. Explain the necessity of Team work in the crisis management in an Industry / Local body.
40. What factors are to be considered while fixing compensation to the workers in the case of severe accidents causing disability / death to them?
41. Explain the legal / financial problems the management has to face if safety measures taken by them are found to be inadequate.
42. Describe the importance of insurance to men and machinery of an Industry dealing with dangerous jobs.
43. What precautions have to be taken while storing explosives in a match/ fire crackers factory?
44. What are the arrangements required for emergency rescue works in the case of Atomic Power Plants?
45. Why residential quarters are not constructed nearer to Atomic Power Plants?

23091 INDUSTRIAL TRAINING –I and 23092 INDUSTRIAL TRAINING –II

Guide Lines

1. Introduction

The main objective of the sandwich Diploma Course is to mould a well rounded technician acclimated with industrial environment while being a student in the institution.

The Sandwich Diploma Course study is pursued by students, in 7 semesters of 3½ years duration, the subjects of 3 years - Full Time Diploma Course being regrouped for academic convenience.

While in the 4th semester students under Industrial Training for 6 months (December through May). They also do course work in the institution for one day in a week, while in the 7th semester they undergo another spell of 6 months (June through November) industrial training.

The Apprenticeship (Amendment) Act 1973 is followed in regulating the Industrial training procedure for Sandwich Course.

I SEM	II SEM	III SEM	IV SEM	V SEM	VI SEM	VII SEM

Institutional Study

Industrial Training

Industrial Training Period

First Spell - IV Semester (December - May)
Second Spell - VII Semester (June - November)

2. Attendance Certification

Every month students have to get their attendance certified by industrial supervisor in the prescribed form supplied to them. Students have also to put their signature on the form and submit it to the institution supervisor. Regularity in attendance and submission of report will be duly considered while awarding the internal marks.

3. Training Reports

The students have to prepare two types of reports;

- Weekly report in the form of diary to be submitted to the concerned staff in charge of the institution. This will be reviewed while awarding Internal marks.
- Comprehensive report at the end of each spell which will be used for Board Examination.

3.1 Industrial Training Diary

Students are required to maintain the record of day - to- day work done. Such record is called Industrial training Diary. Students have to write these reports regularly. All days for the week should be accounted for clearly giving attendance particulars (Presence, Absence, Leave, and Holidays etc). The concern Industrial supervisor is to check periodically these progress reports.

3.2 Comprehensive Training Report

In addition to the diary, students are required to submit a comprehensive report on training with details of the organization where the training was undergone after attestation by the supervisors. The comprehensive report should be incorporating study of plant/ product /process/ construction along with intensive in-depth study on any one of the topics such as processes, methods, tooling, construction and equipment, highlighting aspects of quality, productivity and system. The comprehensive report should be completed in the last week of Industrial training. Any data, drawings etc should be incorporated with the consent of the Organization.

4. Scheme of Evaluation

4.1 Internal Marks

First review (during 3rd month)	: 10 marks
Second review (during 5th month)	: 10 marks
Attendance	: 05 marks (Awarded same as in Theory)

Total : 25 marks

4.2 Board Examination

Presentation about Industrial Training	: 20 marks
Comprehensive Training Report	: 30 marks
Viva-voce	: 25 marks

Total : 75 marks